

# **ANALYSIS OF SMALL-SIGNAL MODEL OF A PWM DC-DC BUCK-BOOST CONVERTER IN CCM.**

A thesis submitted in partial fulfillment

of the requirements for the degree of

**Master of Science in Engineering**

By

**Julie J. Lee**

B.S.EE, Wright State University, Dayton, OH, 2005

**2007**

**Wright State University**

**WRIGHT STATE UNIVERSITY  
SCHOOL OF GRADUATE STUDIES**

August 17, 2007

I HEREBY RECOMMEND THAT THE THESIS PREPARED UNDER MY  
SUPERVISION BY Julie J. Lee ENTITLED Analysis of Small-  
Signal Model of a DC-DC Buck-Boost Converter in CCM  
BE ACCEPTED IN PARTIAL FULFILLMENT OF THE REQUIREMENTS  
FOR THE DEGREE OF Master of Science in Engineering

---

Marian K. Kazimierczuk, Ph.D.  
Thesis Director

---

Fred D. Garber, Ph.D.  
Department Chair

Committee on  
Final Examination

---

Marian K. Kazimierczuk, Ph.D.

---

Kuldip S. Rattan, Ph.D.

---

Ronald Riechers, Ph.D.

---

Joseph F. Thomas, Jr., Ph.D.  
Dean, School of Graduate Studies

## Abstract

Lee, Julie J. M.S. Egr., Department of Electrical Engineering, Wright State University, 2007.  
*Analysis of Small-Signal Model PWM DC-D Buck-Boost Converter in CCM.*

The objective of this research is to analyze and simulate the pulse-width-modulated (PWM) dc-dc buck-boost converter and design a controller to gain stability for the buck-boost converter. The PWM dc-dc buck-boost converter reduces and/or increases dc voltage from one level to a another level in devices that need to, at different times or states, increase or decrease the output voltage.

In this thesis, equations for transfer funtions for a PWM dc-dc open-loop buck-boost converter operating in continuous-conduction-mode (CCM) are derived. For the pre-chosen design, the open-loop characterics and the step responses are studied. The converter is simulated in PSpice to validate the theoretical analysis. AC analysis of the buck-boost converter is performed using theoretical values in MatLab and a discrete point method in PSpice. Three disturbances, change in load current, input voltage, and duty cycle are examined using step responses of the system. The step responses of the output voltage are obtained using MatLab Simulink and validated using PSpice simulation.

Design and simulation of an integral-lead (type III) controller is chosen to reduce dc error and gain stability. Equations for the integral-lead controller are given based on steady-state and AC analysis of the open-loop circuit, with a design method illustrated. The designed controller is implemented in the circuit, and the ac behavior of the system is presented.

Closed loop transfer fuctions are derived for the buck-boost converter. AC analysis of the buck-boost converter is studied using both theoretical values and a discrete point method in PSpice. The step responses of the output voltage due to step change in reference voltage, input voltage and load current are presented. The design and the obtained transfer functions of the PWM dc-dc closed-loop buck-boost converter are validated using PSpice.

# Contents

<b>1</b>	<b>Introduction</b>	<b>1</b>
1.1	Background . . . . .	1
1.2	Thesis Objectives . . . . .	2
<b>2</b>	<b>Open-Loop Buck-Boost</b>	<b>3</b>
2.1	Transfer Functions for Small-Signal Open-Loop Buck-Boost . . . . .	3
2.1.1	Open-Loop Input Control to Output Voltage Transfer Function . . . . .	3
2.1.2	Open-Loop Input Voltage to Output Voltage Transfer Function . . . . .	13
2.1.3	Open-Loop Input Impedance . . . . .	15
2.1.4	Open-Loop Output Impedance . . . . .	21
2.2	Open-Loop Responses of Buck-Boost using MatLab and Simulink . . . . .	23
2.2.1	Open-Loop Response due to Input Voltage Step Change . . . . .	23
2.2.2	Open-Loop Response due to Load Current Step Change . . . . .	28
2.2.3	Open-Loop Response due to Duty Cycle Step Change . . . . .	30
2.3	Open-Loop Responses of Buck-Boost Using PSpice . . . . .	32
2.3.1	Open-Loop Response of Buck-Boost . . . . .	32
2.3.2	Open-Loop Response due to Input Voltage Step Change . . . . .	34
2.3.3	Open-Loop Response due to Load Current Step Change . . . . .	34
2.3.4	Open-Loop Response due to Duty Cycle Step Change . . . . .	36

<b>3</b>	<b>Closed Loop Response</b>	<b>38</b>
3.1	Closed Loop Transfer Functions . . . . .	38
3.1.1	Integral-Lead Control Circuit for Buck-Boost . . . . .	42
3.1.2	Loop Gain of System . . . . .	51
3.1.3	Closed Loop Control to Output Voltage Transfer Function . . . . .	53
3.1.4	Closed Loop Input to Output Voltage Transfer Function . . . . .	53
3.1.5	Closed Loop Input Impedance . . . . .	57
3.1.6	Closed Loop Output Impedance . . . . .	62
3.2	Closed Loop Step Responses of Buck-Boost . . . . .	65
3.2.1	Closed Loop Response due to Input Voltage Step Change . . . . .	65
3.2.2	Closed Loop Response due to Load Current Step Change . . . . .	68
3.2.3	Closed Loop Response due to Reference Voltage Step Change . . . . .	71
3.3	Closed Loop Step Responses using PSpice . . . . .	73
3.3.1	Closed Loop Response of buck-boost . . . . .	73
3.3.2	Closed Loop Response due to Input Voltage Step Change . . . . .	74
3.3.3	Closed Loop Response due to Load Current Step Change . . . . .	76
3.3.4	Closed Loop Response due to Reference Voltage Step Change . . . . .	79
<b>4</b>	<b>Conclusion</b>	<b>81</b>
4.1	Contributions . . . . .	81
4.2	Future Work . . . . .	82
	<b>Appendix A</b>	<b>83</b>
	<b>References</b>	<b>86</b>

# List of Figures

2.1	Small-signal model of buck-boost. . . . .	4
2.2	Block diagram of buck-boost. . . . .	4
2.3	Small-signal model of buck-boost to determine $T_p$ the input control to output voltage transfer function. . . . .	5
2.4	Theoretical open-loop magnitude Bode plot of input control to output voltage transfer function $T_p$ for a buck-boost. . . . .	11
2.5	Open-loop phase Bode plot of input control to output voltage transfer function $T_p$ for a buck-boost with and without $1\mu s$ delay. . . . .	11
2.6	Discrete point open-loop magnitude Bode plot of input control to output voltage transfer function $T_p$ for a buck-boost. . . . .	12
2.7	Discrete points open-loop phase Bode plot of input control to output voltage transfer function $T_p$ for a buck-boost. . . . .	12
2.8	Small-signal model of the buck-boost to determine the input to output voltage transfer function $M_v$ the input to output function. . . . .	13
2.9	Open-loop magnitude Bode plot of input to output voltage transfer function $M_v$ for a buck-boost. . . . .	16
2.10	Open-loop phase Bode plot of input to output transfer function $M_v$ for a buck-boost. . . . .	16

2.11	Open-loop magnitude Bode plot of input to output transfer function $M_v$ for a buck-boost. . . . .	17
2.12	Open-loop phase Bode plot of input to output transfer function $M_v$ for a buck-boost. . . . .	17
2.13	Open-loop magnitude Bode plot of input impedance transfer function $Z_i$ for a buck-boost. . . . .	19
2.14	Open-loop phase Bode plot of input impedance transfer function $Z_i$ for a buck-boost . . . . .	19
2.15	Discrete points open-loop magnitude Bode plot of input impedance transfer function $Z_i$ for a buck-boost. . . . .	20
2.16	Discrete points open-loop phase Bode plot of input impedance transfer function $Z_i$ for a buck-boost. . . . .	20
2.17	Small-signal model of the buck-boost for determining output impedance $Z_o$ . . . . .	21
2.18	Open-loop magnitude Bode plot of output impedance transfer function $Z_o$ for a buck-boost. . . . .	24
2.19	Open-loop phase Bode plot of output impedance transfer function $Z_o$ for a buck-boost . . . . .	24
2.20	Discrete points open-loop magnitude Bode plot of output impedance transfer function $Z_o$ for a buck-boost. . . . .	25
2.21	Discrete points open-loop phase Bode plot of output impedance transfer function $Z_o$ for a buck-boost . . . . .	25
2.22	Open-Loop step response due to step change in input voltage $v_i$ . . . . .	28
2.23	Open-Loop step response due to step change in load current $i_o$ . . . . .	30
2.24	Open-Loop step response due to step change in duty cycle $d$ . . . . .	32
2.25	Open-loop buck-boost model with disturbances. . . . .	33
2.26	Open-loop buck-boost response without disturbances. . . . .	33

2.27	PSpice model of Open-Loop buck-boost with step change in input voltage. . .	34
2.28	Open-Loop step response due to step change in input voltage using PSpice. . .	35
2.29	PSpice model of Open-Loop buck-boost with step change in load current. . .	35
2.30	Open-Loop step response due to step change in load current using PSpice. . .	36
2.31	PSpice model of Open-Loop buck-boost with step change in duty cycle. . . .	37
2.32	Open-Loop step response due to step change in duty cycle using PSpice. . .	37
3.1	Closed loop circuit of voltage controlled buck-boost with PWM. . . . .	39
3.2	Closed loop small-signal model of voltage controlled buck-boost. . . . .	39
3.3	Block diagram of a closed-loop small-signal voltage controlled buck-boost. . .	40
3.4	Simplified block diagram of a closed-loop small-signal voltage controlled buck- boost. . . . .	40
3.5	Magnitude Bode plot of modulator and input control to output voltage transfer function $T_{mp}$ for a buck-boost. . . . .	43
3.6	Phase Bode plot of modulator and input control to output voltage transfer function $T_{mp}$ for a buck-boost. . . . .	43
3.7	Magnitude Bode plot of the input control to output voltage transfer function $T_k$ before the compensator is added for a buck-boost. . . . .	44
3.8	Phase Bode plot of the input control to output voltage transfer function $T_k$ before the compensator is added for a buck-boost. . . . .	44
3.9	The Integral Lead Controller . . . . .	45
3.10	Magnitude Bode plot of the controller transfer function $T_c$ for a buck-boost. . .	52
3.11	Phase Bode plot of the controller transfer function $T_c$ for a buck-boost. . . .	52
3.12	Magnitude Bode plot of the loop gain transfer function $T$ for a buck-boost. . .	54
3.13	Phase Bode plot of the loop gain transfer function $T$ for a buck-boost. . . . .	54
3.14	Magnitude Bode plot of the input control to output transfer function $T_{cl}$ for a buck-boost. . . . .	55

3.15	Phase Bode plot of the input control to output transfer function $T_{cl}$ for a buck-boost. . . . .	55
3.16	Magnitude Bode plot of the input control to output transfer function $T_{cl}$ for a buck-boost. . . . .	56
3.17	Phase Bode plot of the input control to output transfer function $T_{cl}$ for a buck-boost. . . . .	56
3.18	Magnitude Bode plot of the input to output voltage transfer function $M_{vcl}$ for a buck-boost. . . . .	58
3.19	Phase Bode plot of the input to output voltage transfer function $M_{vcl}$ for a buck-boost. . . . .	58
3.20	Magnitude Bode plot of the input to output voltage transfer function $M_{vcl}$ for a buck-boost. . . . .	59
3.21	Phase Bode plot of the input to output voltage transfer function $M_{vcl}$ for a buck-boost. . . . .	59
3.22	Magnitude Bode plot of the input impedance transfer function $Z_{icl}$ for a buck-boost. . . . .	63
3.23	Phase Bode plot of the input impedance transfer function $Z_{icl}$ for a buck-boost.	63
3.24	Magnitude Bode plot of the input impedance transfer function $Z_{icl}$ for a buck-boost. . . . .	64
3.25	Phase Bode plot of the input impedance transfer function $Z_{icl}$ for a buck-boost.	64
3.26	Magnitude Bode plot of the output impedance transfer function $Z_{ocl}$ for a buck-boost. . . . .	66
3.27	Phase Bode plot of the output impedance transfer function $Z_{ocl}$ for a buck-boost.	66
3.28	Magnitude Bode plot of the output impedance transfer function $Z_{ocl}$ for a buck-boost. . . . .	67
3.29	Phase Bode plot of the output impedance transfer function $Z_{ocl}$ for a buck-boost.	67

3.30	Closed Loop step response due to step change in $v_i$ . . . . .	69
3.31	Closed Loop step response due to step change in $i_o$ . . . . .	71
3.32	Closed Loop step response due to step change in $v_r$ . . . . .	73
3.33	Closed loop buck-boost model with disturbances. . . . .	74
3.34	Closed loop buck-boost response without disturbances. . . . .	75
3.35	PSpice model of Closed Loop buck-boost with step change in input voltage. . . . .	76
3.36	Closed Loop step response due to step change in input voltage using PSpice. . . . .	77
3.37	PSpice model of Closed Loop buck-boost with step change in load current. . . . .	77
3.38	Closed Loop step response due to step change in load current using PSpice. . . . .	78
3.39	PSpice model of Closed Loop buck-boost with step change in duty cycle. . . . .	79
3.40	Closed Loop step response due to step change in reference voltage using PSpice. . . . .	80

## **Acknowledgements**

I would like to thank my advisor, Dr. Marian K. Kazimierczuk, for his guidance and input on the thesis development process.

I also wish to thank Dr. Ronald Riechers and Dr. Kuldip S. Rattan for serving as members of my MS thesis defense committee, giving the constructive criticism necessary to produce a quality technical research document.

I would also like to thank the Department of Electrical Engineering and Dr. Fred D. Garber, the Department Chair, for giving me the opportunity to obtain my MS degree at Wright State University.

# 1 Introduction

## 1.1 Background

Trends in the current consumer electronics market demand smaller, more efficient devices. With the increasing use of electronic devices on the market, a demand of low power and low supply voltages is ever increasing. The key for power management is balancing need for less power and lower supply voltages with maintaining operational ability. Many electronic devices require several different voltages and are provided by either a battery or a rectified ac supply line current. However, the voltage is usually not the required, or the ripple voltage could be too high. Voltage regulator methodology is a constant dc voltage despite changes in line voltage, load and temperature.

Voltage regulator can be classified into linear regulators and switching-mode regulators. Some drawbacks of linear regulators are poor efficiency, which also leads to excess heat dissipation and it is impossible to generate voltages higher than the supply voltage. Switching-mode regulators can be separated into the following categories: Pulse-Width Modulated (PWM) dc-dc regulators, Resonant dc-dc converters, and Switched-capacitor voltage regulators. The PWM dc-dc regulators can be divided into three important topologies: buck converter, boost converter, and buck-boost converter. The buck-boost converter is chosen for analysis.

The PWM dc-dc buck-boost converter reduces and increases dc voltage from one level to another [1]-[5]. A buck-boost converter can operate in both continuous conduction mode

(CCM), which is the state discussed, and discontinuous conduction mode (DCM) depending on the inductor current waveform. In CCM, the inductor current flows continuously for the entire period, whereas in DCM, the inductor current reduces to zero and stays at zero for the rest of the period before it begins to rise again.

## **1.2 Thesis Objectives**

The objectives of this thesis are as follows:

1. To analyze and simulate the dc-dc buck-boost converter for open-loop.
2. To design a control circuit for the buck-boost converter.
3. To analyze and simulate the dc-dc buck-boost converter for closed-loop.

## 2 Open-Loop Buck-Boost

Derived small-signal open-loop transfer functions for the input control to output voltage transfer function  $T_p$ , audio susceptibility  $M_v$ , input impedance  $Z_i$  and output impedance  $Z_o$ . Using the transfer functions finding the AC analysis of the transfer function by finding the Bode plots. Step responses of the system are found due to a step change in input voltage  $v_i$ , duty cycle  $d$  and load current  $i_o$ .

### 2.1 Transfer Functions for Small-Signal Open-Loop Buck-Boost

#### 2.1.1 Open-Loop Input Control to Output Voltage Transfer Function

A small-signal open-loop buck-boost model is shown in Fig 2.1. A block diagram of a buck-boost converter is shown in Fig 2.2. The MOSFET and diode are replaced by a small-signal model of a switching network (dependent voltage and current sources), the inductor is replaced by a short and the capacitor is replaced by an open circuit. The pre-chosen measured values of the circuit are:  $V_I = 48 \text{ V}$ ,  $D = 0.407$ ,  $V_F = 0.7 \text{ V}$ ,  $r_{DS} = 0.4 \text{ } \Omega$ ,  $R_F = 0.02 \text{ } \Omega$ ,  $L = 334 \text{ mH}$ ,  $C = 68 \text{ } \mu\text{F}$ ,  $r_C = 0.033 \text{ } \Omega$ , and  $R_L = 14 \text{ } \Omega$ .

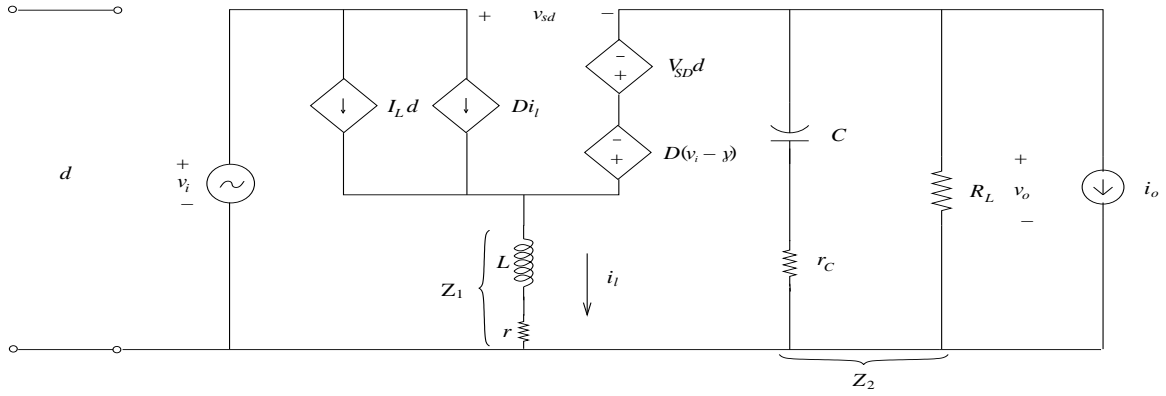

Figure 2.1: Small-signal model of buck-boost.

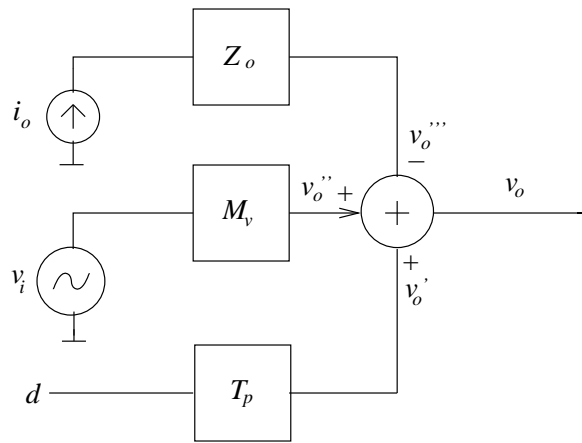

Figure 2.2: Block diagram of buck-boost.

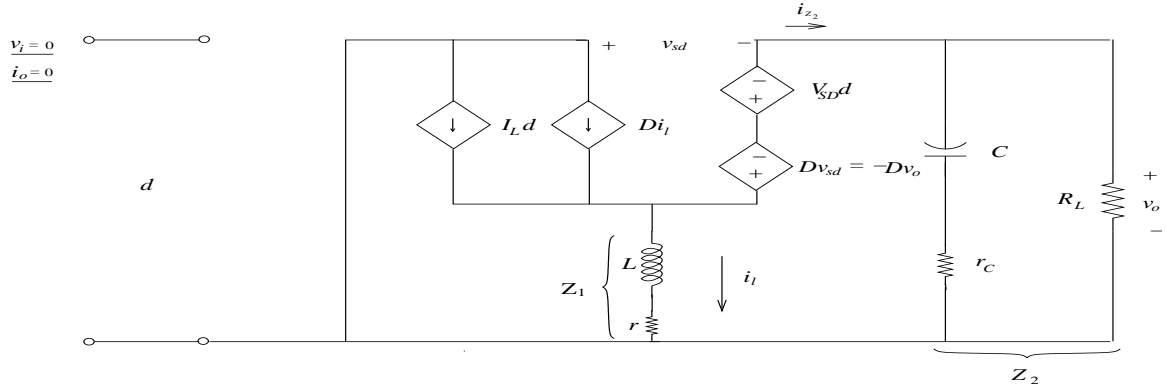

Figure 2.3: Small-signal model of buck-boost to determine  $T_p$  the input control to output voltage transfer function.

The dependent sources are related to duty cycle. Setting the other two inputs to zero relates the control input to the output. This transfer function due to duty cycle affecting the output is  $T_p$ . The derivation using Fig 2.3 of  $T_p$  is below starting from first principles of KCL and KVL.

Finding the transfer function of the plant  $T_p$

$$i_{Z_2} = \frac{v_{z_2}}{Z_2} = \frac{v_o}{Z_2} \quad (2.1)$$

Using KCL

$$i_l + i_{z_2} - I_L d - D i_l = 0$$

$$i_l(1 - D) + i_{z_2} - I_L d = 0 \quad (2.2)$$

$$i_l Z_1 - V_{SD} d - D v_{sd} = v_o \quad (2.3)$$

$$v_{sd} = -v_o \quad (2.4)$$

$$i_l Z_1 = v_o + V_{SD} d - D v_o$$

$$i_l = \frac{v_o(1-D) + v_{sd}d}{Z_1} \quad (2.5)$$

Substituting values

$$\frac{v_o(1-D) + V_{SD}d}{Z_1}(1-D) + \frac{v_o}{Z_2} - I_L d = 0 \quad (2.6)$$

$$\frac{v_o(1-D)^2}{Z_1} + \frac{+V_{SD}d(1-D)}{Z_1} + \frac{v_o}{Z_2} - I_L d = 0$$

$$v_o \left[ \frac{(1-D)^2}{Z_1} + \frac{1}{Z_2} \right] = d \left[ I_L - \frac{V_{SD}(1-D)}{Z_1} \right]$$

$$T_p \equiv \frac{v_o(s)}{d(s)} \Big|_{v_o=i_o=0} = \frac{\left( I_L - \frac{V_{SD}(1-D)}{Z_1} \right)}{\left( \frac{(1-D)^2}{Z_1} + \frac{1}{Z_2} \right)} = \frac{I_L \left( 1 - \frac{V_{SD}(1-D)}{I_L} \right)}{(1-D)^2 + \frac{Z_1}{Z_2}} \quad (2.7)$$

$$I_l = \frac{I_D}{(1-D)} = -\frac{I_o}{(1-D)} = -\frac{v_o}{(1-D)R_L} \quad (2.8)$$

Using KVL

$$rI_L - Dv_{sd} + v_F - v_o = 0 \quad (2.9)$$

$$v_{sd} - v_I - v_F + v_o = 0 \quad \therefore \quad v_{sd} = v_I + v_F - v_o \quad (2.10)$$

Substituting values

$$r \left[ \frac{-v_o}{(1-D)R_L} \right] - D(v_I + v_F - v_o) + v_F - v_o = 0 \quad (2.11)$$

$$r \left[ \frac{-v_o}{(1-D)R_L} \right] + Dv_F - v_o + v_F - v_o = Dv_I$$

$$-v_o \left[ \frac{r}{(1-D)R_L} - v_I D - \frac{v_F}{v_o} + 1 + D \left( \frac{v_F}{v_o} \right) \right] = v_I D$$

$$-v_o \left[ \frac{r}{(1-D)R_L} + (1-D) \left( 1 - \frac{v_F}{v_o} \right) \right] = v_I D$$

$$v_{sd} = v_I + v_F - v_o = -v_o \left( 1 - \frac{v_F}{v_o} - \frac{v_I}{v_o} \right) = I_L R_L (1-D) \left( 1 - \frac{v_F}{v_o} - \frac{1}{M_{VDC}} \right)$$

$$\frac{v_{sd}}{I_L} = \frac{1}{D} \left[ R_L (1-D) \left( 1 + \frac{v_F}{|v_o|} + r \right) \right]$$

$$T_p(s) \equiv \frac{v_o}{d} \Big|_{v_i=i_o=0} = \frac{I_L \left( 1 - \frac{v_{sd}(1-D)}{I_L} \right)}{(1-D)^2 + \frac{Z_1}{Z_2}}$$

$$T_p(s) = \frac{I_L \left[ Z_1 - (1-D) \frac{v_{sd}}{I_L} \right]}{\frac{Z_1}{Z_2} + (1-D)^2}$$

$$T_p(s) = \frac{I_L \left[ Z_1 - (1-D) \frac{v_{sd}}{I_L} \right]}{\frac{Z_1 + (1-D)^2 Z_2}{Z_2}} = \frac{I_L \left[ Z_1 - (1-D) \frac{v_{sd}}{I_L} \right] Z_2}{Z_1 + (1-D)^2 Z_2} \quad (2.12)$$

$$Z_1 = r + sL \quad (2.13)$$

$$Z_2 = \frac{R_L \left( r_c + \frac{1}{sC} \right)}{R_L + r_c + \frac{1}{sC}} \quad (2.14)$$

$$\frac{v_{sd}}{I_L} = \frac{1}{D} \left[ R_L(1-D) \left( 1 + \frac{v_F}{|v_o|} \right) + r \right] \quad (2.15)$$

$$I_L = \frac{-v_o}{(1-D)R_L} \quad (2.16)$$

$$T_p = \frac{I_L \left[ Z_1 - (1-D) \frac{v_{sd}}{I_L} \right] Z_2}{Z_1 + (1-D)^2 Z_2} \quad (2.17)$$

$$DenT_p = (r + sL) + (1-D)^2 \frac{R_L \left( r_c + \frac{1}{sC} \right)}{R_L + r_c + \frac{1}{sC}}$$

$$DenT_p = \left( R_L + r_c + \frac{1}{sC} \right) (r + sL) + (1-D)^2 R_L \left( r_c + \frac{1}{sC} \right)$$

$$= R_L r + r r_c + r \frac{1}{sC} + sL R_L + sL r_c + \frac{L}{C} + (1-D)^2 \left( R_L r_c + \frac{R_L}{sC} \right)$$

$$= sC R_L r + sC r_c r + r + s^2 C L R_L + s^2 L C r_c + sL + (1-D)^2 (sC R_L r_c + R_L)$$

$$= s^2 + \frac{C \left[ r(R_L + r_c) + (1-D)^2 R_L r_c \right] + L}{LC(R_L + r_c)} s + \frac{r + (1-D)^2 R_L}{LC(R_L + r_c)} \quad (2.18)$$

$$NumT_p = (sC) \left[ \frac{1}{LC(R_L + r_c)} \right] I_L \left[ \frac{R_L \left( r_c + \frac{1}{sC} \right)}{R_L + r_c + \frac{1}{sC}} \right] \left[ R_L + r_c + \frac{1}{sC} \right] \left[ Z_1 - (1-D) \frac{v_{sd}}{I_L} \right]$$

$$= I_L (R_L (sC r_c + 1) (r + sL)) - \frac{1}{D} \left[ R_L (1-D)^2 \left( 1 + \frac{v_F}{|v_o|} + r \right) \right] \left[ \frac{1}{LC(R_L + r_c)} \right]$$

$$= -\frac{V_o}{(1-D)R_L} (R_L(sCr_C + 1)) \left( \frac{1}{LC(R_L + r_C)} \right) (L) \left[ s - \frac{1}{DL} \left( R_L(1-D)^2 \left( 1 + \frac{v_F}{|v_o|} \right) + r(1-2D) \right) \right]$$

$$NumT_p = -\frac{V_o}{((1-D)R_L + r_C)} \left( s + \frac{1}{Cr_C} \right) \left[ s - \frac{1}{DL} (R_L(1-D)^2 \left( 1 + \frac{v_F}{|v_o|} \right) + r(1-2D)) \right] \quad (2.19)$$

$$\zeta = \frac{C [r(R_L + r_C) + (1-D)^2 R_L r_C] + L}{2\sqrt{LC(R_L + r_C)} [r + (1-D)^2 R_L]} \quad (2.20)$$

$$\omega_o = \sqrt{\frac{r + (1-D)^2 R_L}{LC(R_L + r_C)}} \quad (2.21)$$

$$\omega_{zn} = -\frac{1}{Cr_C} \quad (2.22)$$

$$\omega_{zp} = \frac{1}{DL} \left[ R_L(1-D)^2 \left( 1 + \frac{v_F}{|v_o|} \right) + r(1-2D) \right] \quad (2.23)$$

$$T_p \equiv \frac{v_o}{d} |_{v_i=i_o=0} = -\frac{V_o}{(1-D)(R_L + r_C)} \frac{(s + \omega_{zn})(s + \omega_{zp})}{s^2 + 2\zeta\omega_o s + \omega_o^2} \quad (2.24)$$

$$T_{px} = -\frac{V_o}{(1-D)(R_L + r_C)} \quad (2.25)$$

$$T_{po} = T_p(0) = \frac{-V_o R}{(1-D)(R_L + r_C)} \frac{\omega_{zn} \omega_{zp}}{\omega_o^2}$$

$$= \frac{V_o r_C}{(1-D)(R_L + r_C)} \left[ \frac{\left( -\frac{1}{Cr_C} \right) \frac{1}{DL} \left( R_L(1-D)^2 \left( 1 + \frac{v_F}{|v_o|} \right) + r(1-2D) \right)}{\frac{r + (1-D)^2 R_L}{LC(R_L + r_C)}} \right]$$

$$\begin{aligned}
&= \frac{V_o r_C}{(1-D)(R_L + r_C)} \left[ \frac{\left( R_L(1-D)^2 \left( 1 + \frac{v_F}{|v_o|} \right) + r(1-2D) \right)}{\frac{CDLr_C}{\frac{r+(1-D)^2 R_L}{LC(R_L+r_C)}}} \right] \\
T_{po} &= \frac{V_o}{D(1-D)} \left[ \frac{R_L(1-D)^2 \left( 1 + \frac{v_F}{|v_o|} \right) + r(1-2D)}{r + (1-D)^2 R_L} \right] \tag{2.26}
\end{aligned}$$

The Bode plot of  $T_p$  is shown in Fig 2.4 and 2.5.

The input control to output voltage transfer function  $T_p$  has a non-minimum phase system due to the right hand plane zero. The complex pole of the system is dependent on duty cycle,  $D$ . The Bode plots for input control to output voltage transfer function  $T_p$  is also found using discrete points. Discrete points were used rather than sweeping the circuit because PSpice sweeps are only accurate for linearized circuits. Therefore, a sinusoidal source was inserted, and the magnitude of ripples in either the voltage or the current are used to determine the magnitude of the function. Phase of the function was found by determining the time difference between the two signals of interest. Distinguishing the ripple from the noise was a challenge to be overcome. The answer was to boost the signal voltage but still maintain the small-signal condition of the system. Therefore, for this thesis, a magnitude value of ten or less volts for the test voltage is considered a small-signal. Most test voltages did not need to exceed five volts to distinguish between the noise and ripple. The only one that required a higher value is  $Z_{ict}$ , which is caused by the MOSFET being placed in series with the sinusoidal voltage source. In addition the MOSFET has a floating node associated with it. Figs 2.6 and 2.7 show the discrete point Bode plots of the control input to output voltage transfer function  $T_p$ .

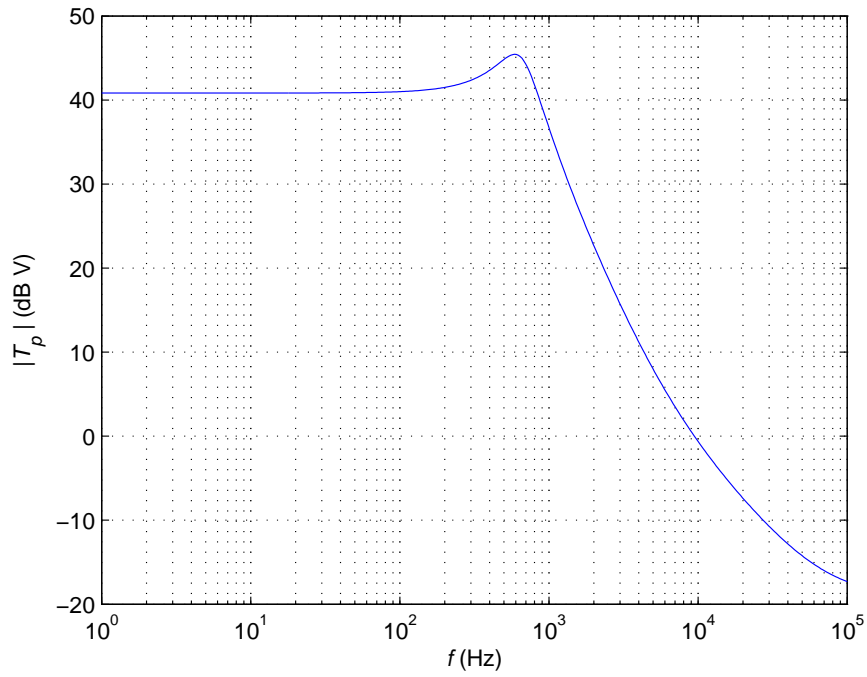

Figure 2.4: Theoretical open-loop magnitude Bode plot of input control to output voltage transfer function  $T_p$  for a buck-boost.

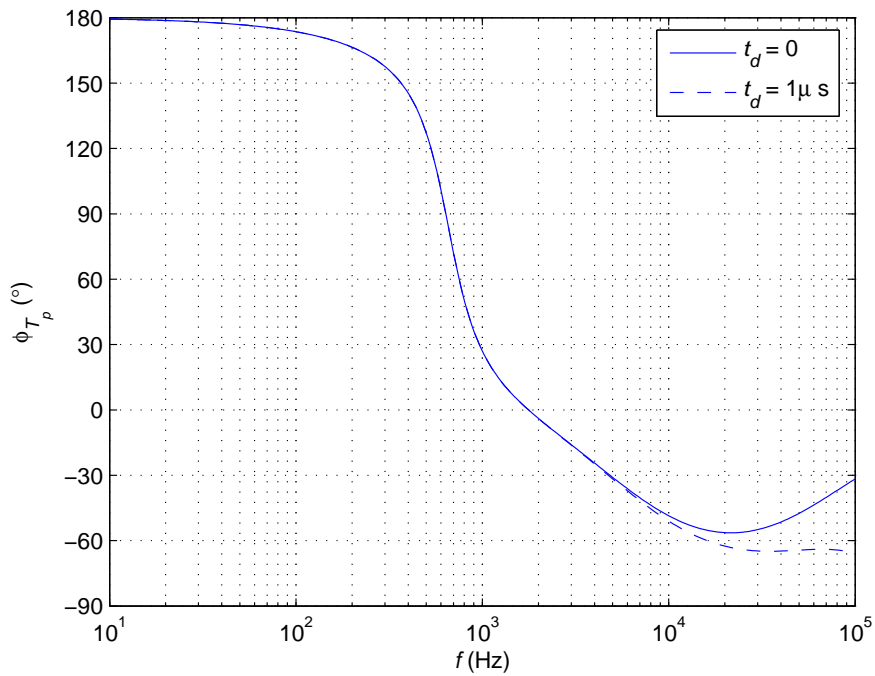

Figure 2.5: Open-loop phase Bode plot of input control to output voltage transfer function  $T_p$  for a buck-boost with and without  $1\mu\text{s}$  delay.

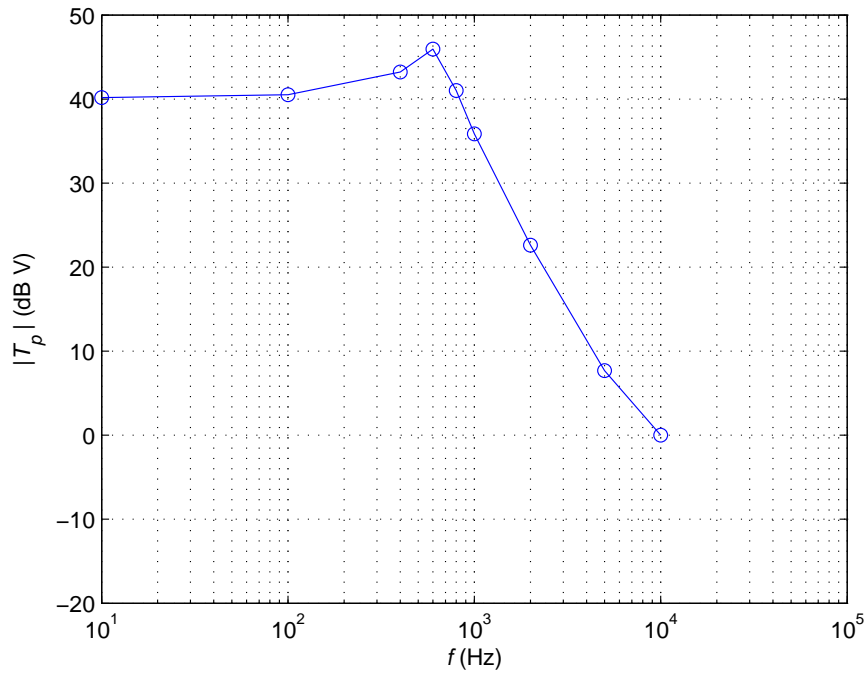

Figure 2.6: Discrete point open-loop magnitude Bode plot of input control to output voltage transfer function  $T_p$  for a buck-boost.

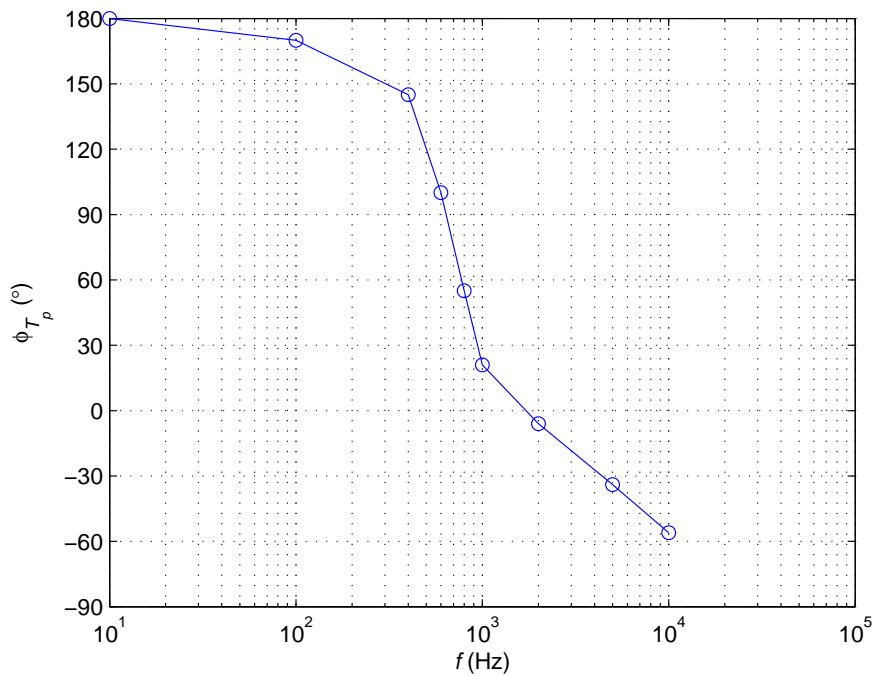

Figure 2.7: Discrete points open-loop phase Bode plot of input control to output voltage transfer function  $T_p$  for a buck-boost.

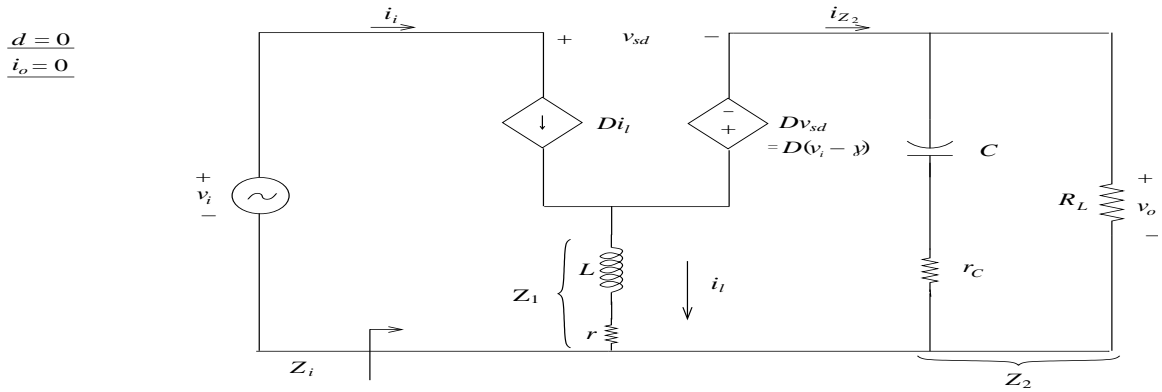

Figure 2.8: Small-signal model of the buck-boost to determine the input to output voltage transfer function  $M_v$  the input to output function.

## 2.1.2 Open-Loop Input Voltage to Output Voltage Transfer Function

A small-signal model of a buck-boost converter with inputs  $d = 0$  and  $i_o = 0$  is shown in Fig 2.8.

Using this model to derive equations for the input voltage to out voltage transfer function  $M_v$ , also known as audio susceptibility. Again, using first principles to start the derivation process.

From KCL

$$i_l - Di_l + i_{Z_2} = 0 \quad (2.27)$$

$$i_{Z_2} = \frac{v_o}{Z_2} \quad (2.28)$$

$$i_l = -\frac{i_{Z_2}}{(1-D)} = -\frac{v_o}{(1-D)Z_2} \quad (2.29)$$

Using KVL

$$-i_l Z_1 + v_o + Dv_{sd} = 0$$

$$i_l Z_1 = v_o + D(v_i - v_o)$$

$$i_l Z_1 = Dv_i + (1 - D)v_o$$

$$-\frac{v_o}{Z_2(1 - D)} Z_1 = Dv_i + (1 - D)v_o$$

$$Dv_i = -(1 - D)v_o \left[ 1 + \frac{Z_1}{Z_2(1 - D)^2} \right]$$

$$\begin{aligned} M_v(s) &\equiv \frac{v_o(s)}{v_i(s)} \Big|_{d=i_o=0} = -\frac{D}{(1 - D) \left[ 1 + \frac{Z_1}{Z_2(1 - D)^2} \right]} \\ &= -\frac{D}{(1 - D)} \frac{1}{1 + \frac{Z_1}{Z_2(1 - D)^2}} = -\frac{D}{(1 - D)} (1 - D)^2 \left[ \frac{1}{(1 - D) + \frac{Z_1}{Z_2}} \right] \\ M_v &= \frac{(1 - D)DR_L r_C}{L(R_L + r_C)} \frac{s + \omega_{zn}}{s^2 + 2\zeta \omega_o s + \omega_o^2} \end{aligned} \quad (2.30)$$

$$M_{vx} = \frac{(1 - D)DR_L r_C}{L(R_L + r_C)} \quad (2.31)$$

$$\begin{aligned} M_{vo} = M_v(0) &= -\frac{(1 - D)DR_L r_C}{L(R_L + r_C)} \frac{\omega_{zn}}{\omega_o^2} \\ &= -\frac{(1 - D)DR_L r_C}{L(R_L + r_C)} \left[ \frac{\frac{1}{C r_C}}{\frac{r + (1 - D)^2 R_L}{LC(R_L + r_C)}} \right] \end{aligned}$$

$$M_{vo} = -\frac{(1-D)DR_L}{r + (1-D)^2R_L} \quad (2.32)$$

Fig: 2.9 and 2.10 show the theoretical Bode plots of  $M_v$ .

Using PSpice to determine certain points of interest gives the following Bode plot shown in figures 2.11 and 2.12.

### 2.1.3 Open-Loop Input Impedance

Finding the input impedance  $Z_i$  for the open-loop buck-boost converter circuit. Using Fig 2.8 to derive the open-loop impedance of the buck-boost small-signal model.

Using KCL

$$Di_l - i_l - i_{Z_2} = 0$$

$$i_{Z_2} = Di_l - i_l$$

$$i_{Z_2} = -(1-D)i_l \quad (2.33)$$

From KVL

$$-Z_1i_l + D(v_i - v_o) + v_o = 0$$

$$-Z_1i_l + Dv_{io}(1-D) = 0$$

$$-i_lZ_1 + Dv_i - i_l(1-D)(1-D)Z_2 = 0$$

$$-i_lZ_1 + Dv_i - i_l(1-D)^2Z_2 = 0$$

$$Dv_i = i_l(Z_1 + (1-D)^2Z_2)$$

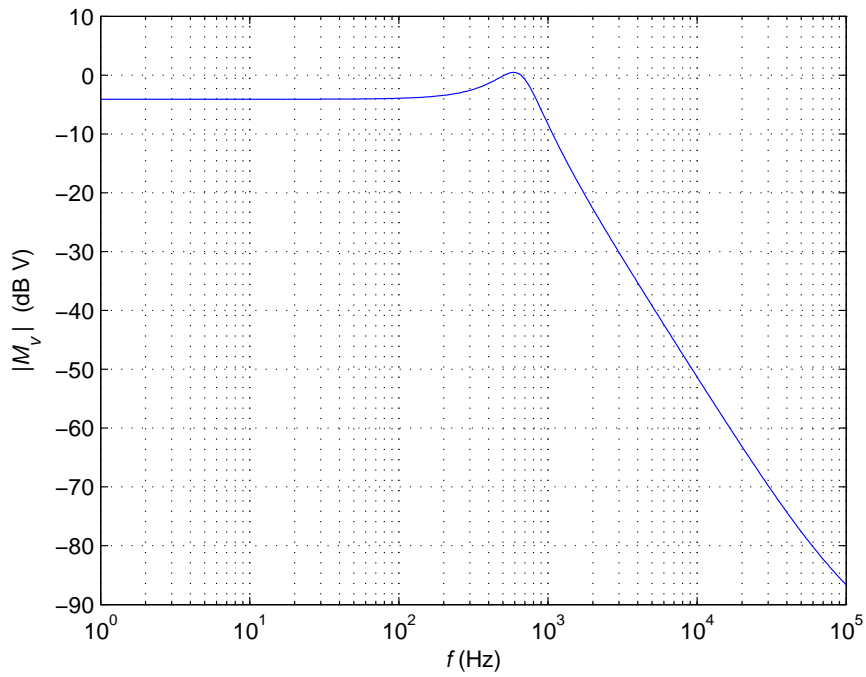

Figure 2.9: Open-loop magnitude Bode plot of input to output voltage transfer function  $M_v$  for a buck-boost.

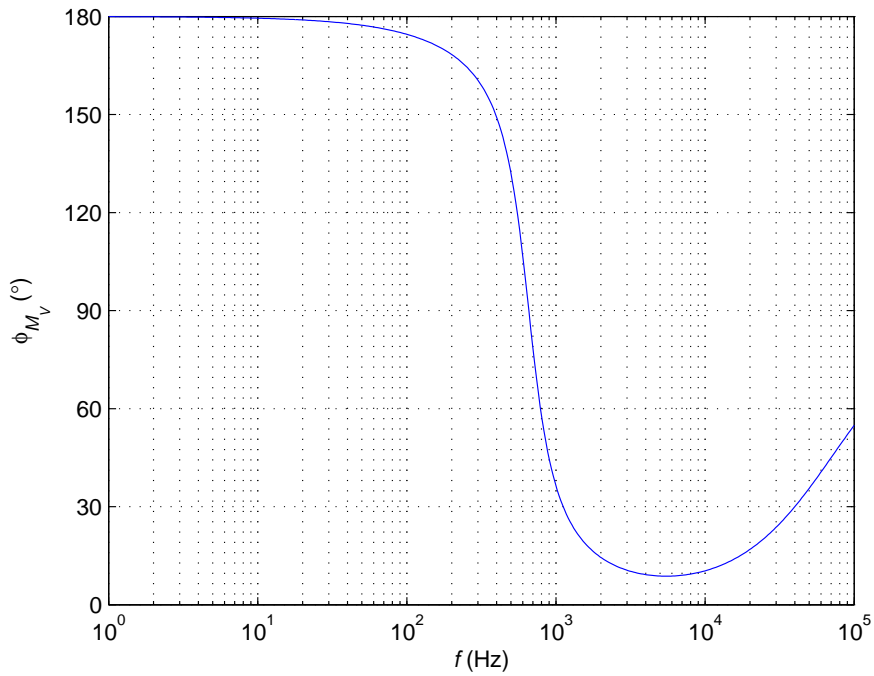

Figure 2.10: Open-loop phase Bode plot of input to output transfer function  $M_v$  for a buck-boost.

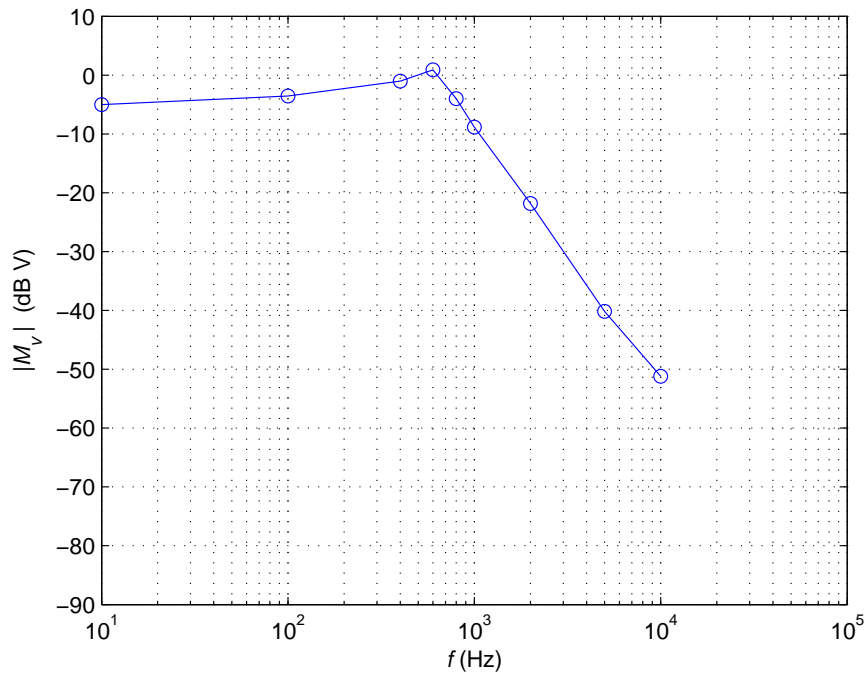

Figure 2.11: Open-loop magnitude Bode plot of input to output transfer function  $M_v$  for a buck-boost.

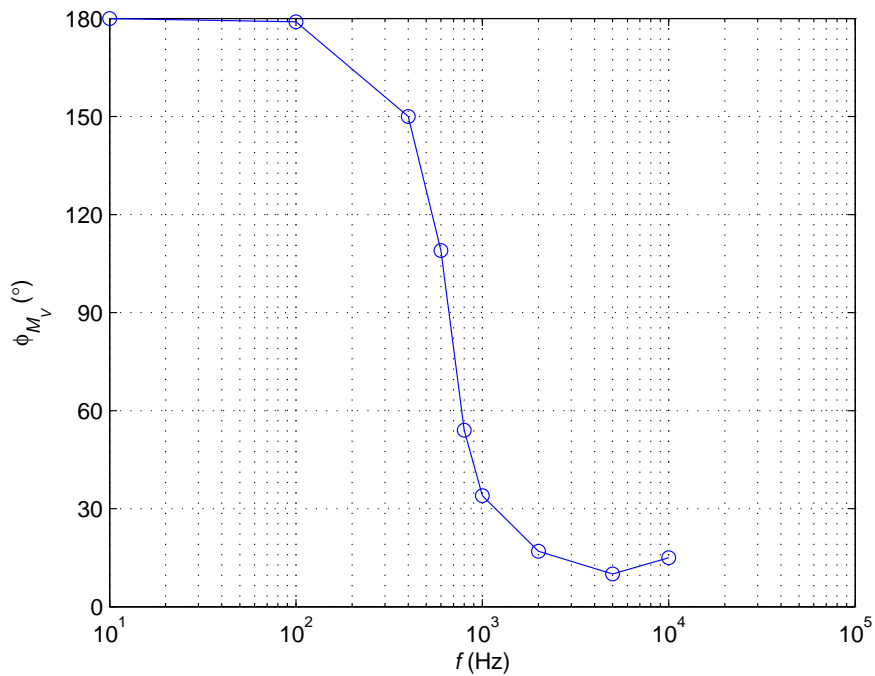

Figure 2.12: Open-loop phase Bode plot of input to output transfer function  $M_v$  for a buck-boost.

$$\begin{aligned}
Z_i &= \frac{v_i}{i_i} = \frac{(Z_1 + (1-D)^2 Z_2)}{D^2} \\
&= \frac{1}{D^2} \left[ r + sL + \frac{r + (1-D)^2 R_L}{LC(R_L + r_C)} (1-D)^2 \right] \\
&= \frac{(r + sL)(R_L + r_C + \frac{1}{sC}) + R_L(r_C + \frac{1}{sC})(1-D)^2}{D^2(R_L + r_C + \frac{1}{sC})} \\
&= \frac{1}{D^2} \left[ \frac{rR_L + rr_C + \frac{r}{sC} + sLR_L + sLr_C + \frac{L}{C} + R_Lr_C(1-D)^2 + (1-D)^2 \frac{R_L}{sC}}{R_L + r_C + \frac{1}{sC}} \right] \\
&= \frac{1}{D^2} \frac{LC(R_L + r_C)s^2 + [C(r(r_C + R_L) + R_Lr_C(1-D)^2) + L]s + R_L(1-D)^2 + r}{sCR_L + sCr_C + 1} \\
Z_i &= \frac{1}{D^2(LC(R_L + r_C))} \frac{\left( s^2 + \frac{C(r(R_L + r_C) + R_Lr_C(1-D)^2) + L}{LC(R_L + r_C)} s + \frac{R_L(1-D)^2 + r}{LC(R_L + r_C)} \right)}{sC(R_L + r_C) + 1}
\end{aligned}$$

where

$$\omega_{rc} = \frac{1}{C(R_L + r_C)} \quad (2.34)$$

$$Z_i = \frac{L}{D^2} \frac{s^2 + 2\zeta\omega_o s + \omega_o^2}{s + \omega_{rc}} \quad (2.35)$$

Figs: 2.13 and 2.14 show the theoretical Bode plots of  $Z_i$ .

As shown above the Magnitude of  $|Z_i|$  decreases quickly with an increase in  $D$ .

Figs 2.15 and 2.16 show the discrete point Bode plots for  $Z_i$ .

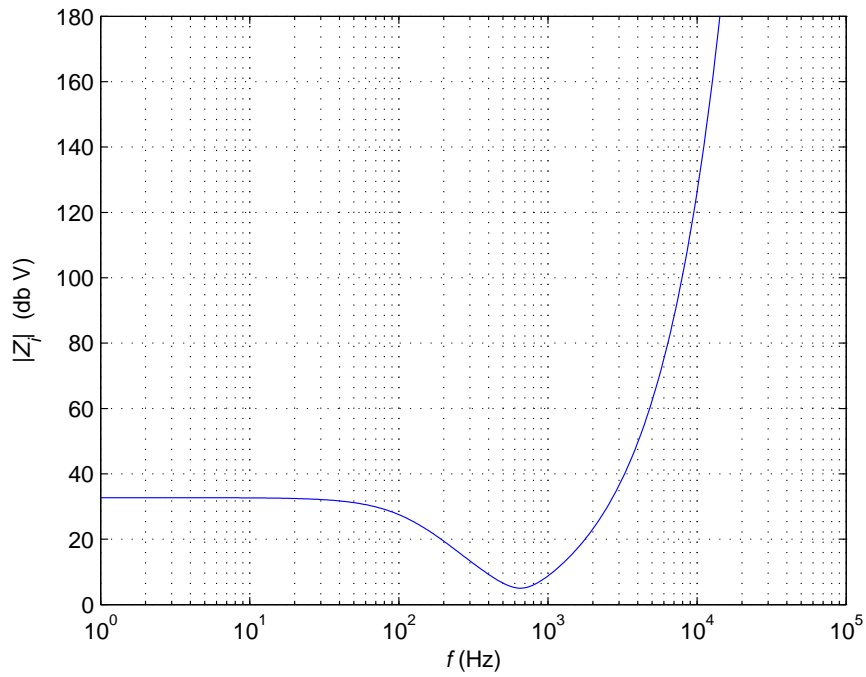

Figure 2.13: Open-loop magnitude Bode plot of input impedance transfer function  $Z_i$  for a buck-boost.

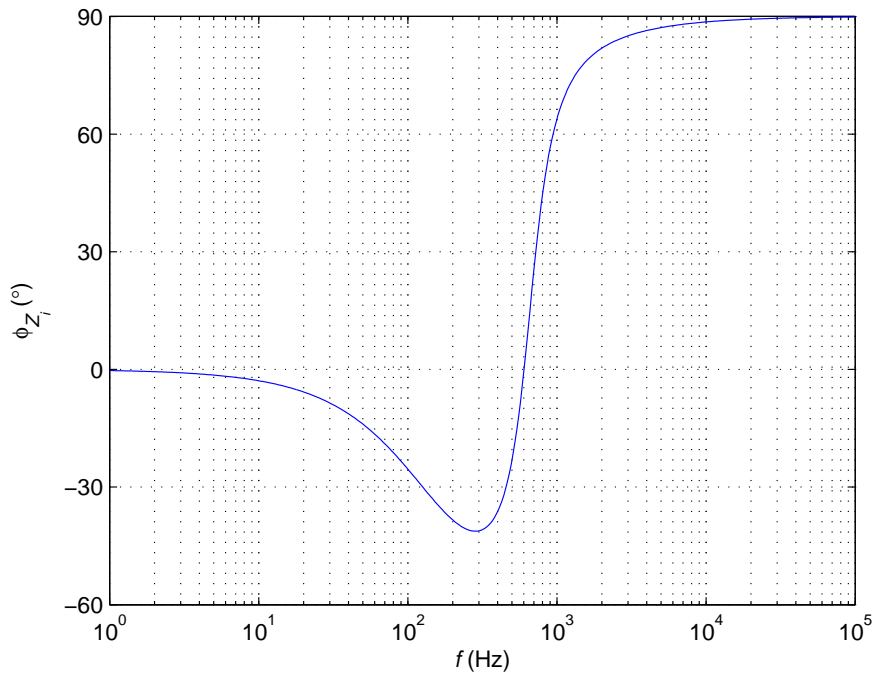

Figure 2.14: Open-loop phase Bode plot of input impedance transfer function  $Z_i$  for a buck-boost

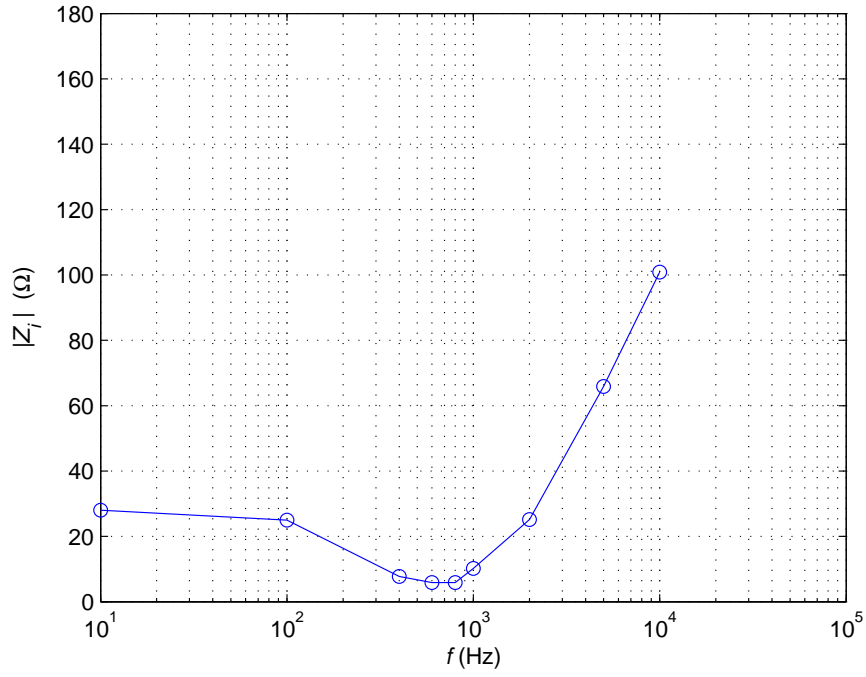

Figure 2.15: Discrete points open-loop magnitude Bode plot of input impedance transfer function  $Z_i$  for a buck-boost.

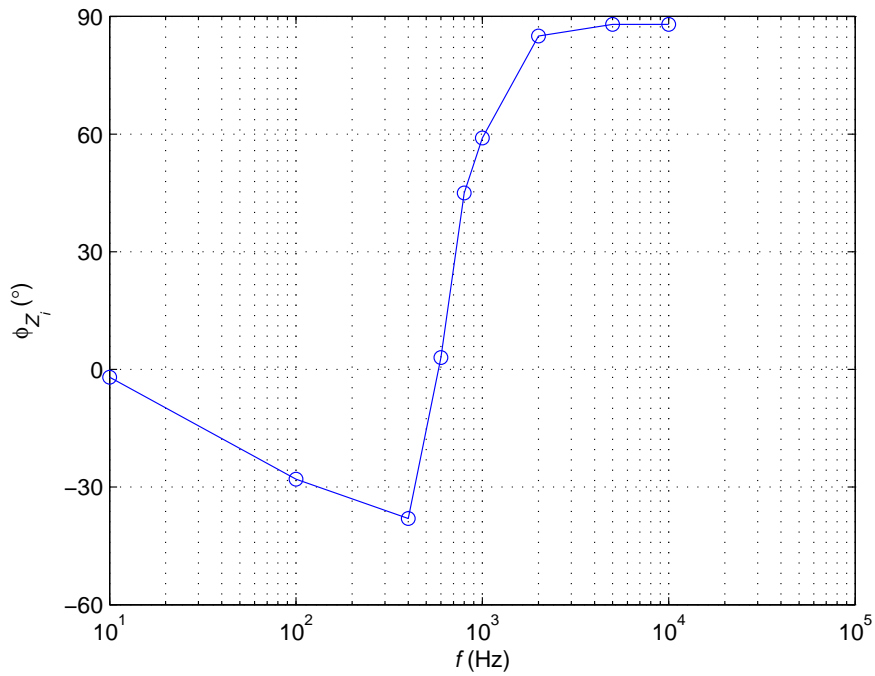

Figure 2.16: Discrete points open-loop phase Bode plot of input impedance transfer function  $Z_i$  for a buck-boost.

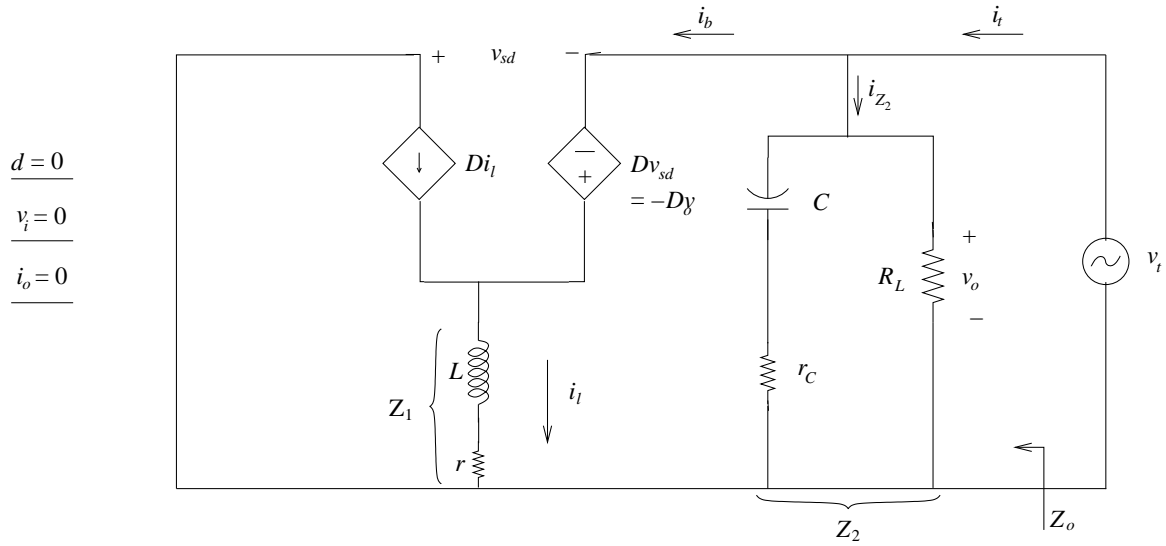

Figure 2.17: Small-signal model of the buck-boost for determining output impedance  $Z_o$ .

## 2.1.4 Open-Loop Output Impedance

Solving for the transfer function of output impedance  $Z_o$ . Output impedance  $Z_o$  of the buck-boost small-signal model is shown in Fig 2.17 where all three inputs  $d$ ,  $v_i$ , and  $i_o$  equal 0. A test voltage  $v_t$  with a current of  $i_t$  is applied to the output of the model. The ratio of  $v_t$  to  $i_t$  determines  $Z_o$ .

Using KVL

$$-Z_1 i_l - Dv_t + v_t = 0 \quad (2.36)$$

$$i_l = \frac{(1-D)v_t}{Z_1} \quad (2.37)$$

KCL

$$i_b + i_{Z_2} - i_t = 0$$

$$i_b = (1-D)i_l \quad (2.38)$$

$$(1-D)i_t = i_t - i_{Z_2}$$

$$\frac{(1-D)^2 v_t}{Z_1} = i_t - \frac{v_t}{Z_2}$$

$$v_t \left( c + \frac{1}{Z_2} \right) = i_t \quad (2.39)$$

$$\begin{aligned} Z_o &= \frac{v_t}{i_t} = \frac{1}{\frac{1}{Z_2} + \frac{(1-D)^2}{Z_1}} = \frac{Z_1}{\frac{Z_1}{Z_2} + (1+D)^2} \\ &= \frac{(r+sL) \left( \frac{R_L(r_C + \frac{1}{sC})}{R_L + r_C + \frac{1}{sC}} \right)}{r+sL + \frac{R_L(r_C + \frac{1}{sC})}{R_L + r_C + \frac{1}{sC}} (1-D)^2} \\ &= \frac{(r+sL) \left( R_L \left( r_C + \frac{1}{sC} \right) \right)}{(r+sL) \left[ R_L \left( r_C + \frac{1}{sC} \right) \right] + R_L (1-D)^2 \left( r_C + \frac{1}{sC} \right)} \\ &= \frac{1}{LC(R_L + r_C)} \frac{s^2 + \frac{CrR_L r_C + LR_L}{LCR_L r_C} s + \frac{rR_L}{LCR_L r_C}}{s^2 + 2\zeta \omega_o s + \omega_o^2} \\ Z_o &= \frac{1}{LC(R_L + r_C)} \frac{\left( s + \frac{r}{L} \right) \left( s + \frac{1}{Cr_C} \right)}{s^2 + 2\zeta \omega_o s + \omega_o^2} \end{aligned}$$

$$\omega_{rL} = \frac{r}{L} \quad (2.40)$$

$$\omega_{zn} = \frac{1}{Cr_C} \quad (2.41)$$

$$Z_o \equiv \frac{v_t}{i_t} = \frac{R_L r_C}{(R_L + r_C)} \frac{(s + \omega_{rL})(s + \omega_{zn})}{s^2 + 2\zeta \omega_o s + \omega_o^2} \quad (2.42)$$

Figs: 2.18 and 2.19 show the Bode plots for  $Z_o$ .

As  $D$  increases so does the magnitude of  $|Z_o|$  at low frequencies.

Figs: 2.18 and 2.19 show the discrete points PSpice simulated Bode plots for  $Z_o$ .

## 2.2 Open-Loop Responses of Buck-Boost using MatLab and Simulink

### 2.2.1 Open-Loop Response due to Input Voltage Step Change

Response of output voltage  $v_o$  due to a step change of 1 Volt in input voltage  $v_i$ . The total input voltage is given by equation 3.40 where  $u(t)$  is the unit step function and  $V_I(0^-)$  is the input voltage before applying the step voltage.

$$v_I(t) = V_I(0^-) + \Delta V_I u(t) \quad (2.43)$$

rearranging  $T_{\{p\}}$  open-loop input control to output voltage transfer function

$M_{\{v\}}$  open-loop input to output voltage transfer function, audio susceptibility

$Z_{\{i\}}$  open-loop input impedance transfer function

$Z_{\{o\}}$  open-loop output impedance transfer function

$$v_i(t) = \Delta V_I u(t) = v_I(t) - V_I(0^-) \quad (2.44)$$

Changing from time domain to s-domain

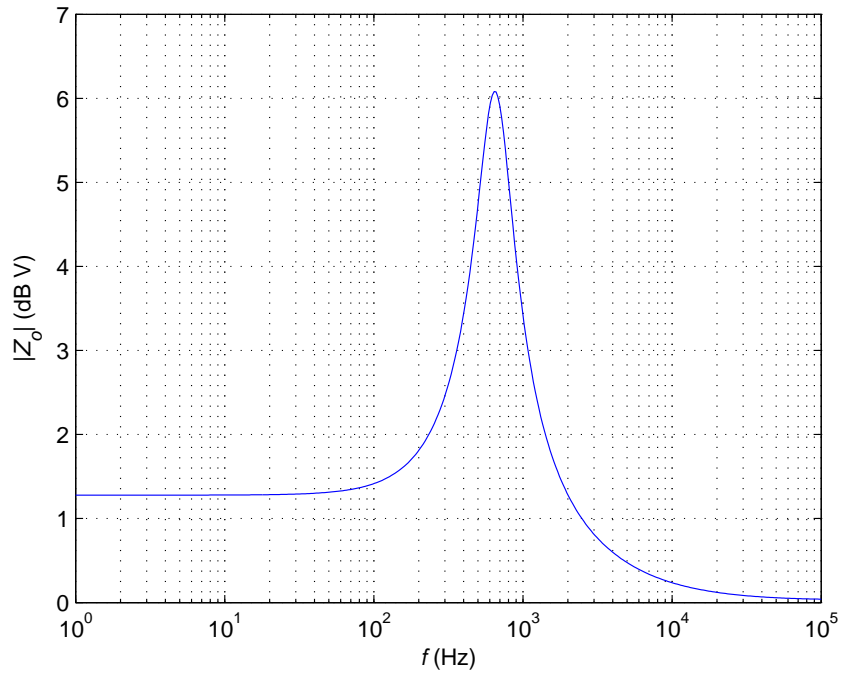

Figure 2.18: Open-loop magnitude Bode plot of output impedance transfer function  $Z_o$  for a buck-boost.

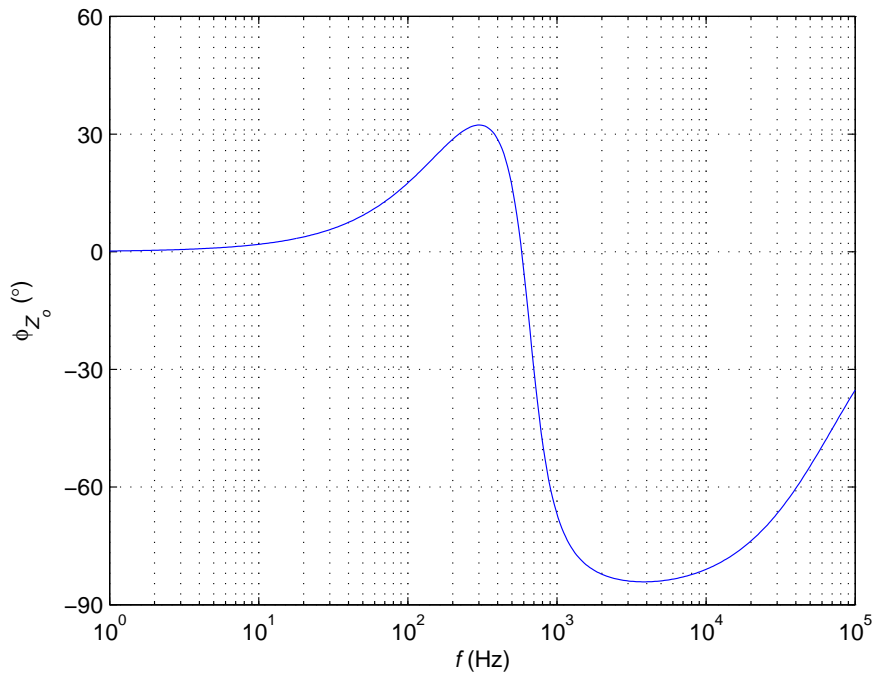

Figure 2.19: Open-loop phase Bode plot of output impedance transfer function  $Z_o$  for a buck-boost

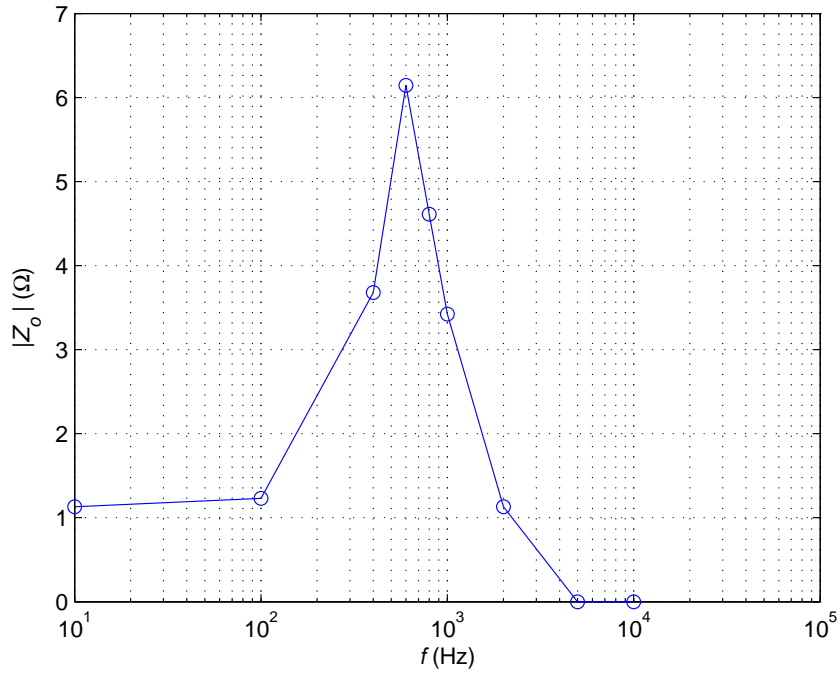

Figure 2.20: Discrete points open-loop magnitude Bode plot of output impedance transfer function  $Z_o$  for a buck-boost.

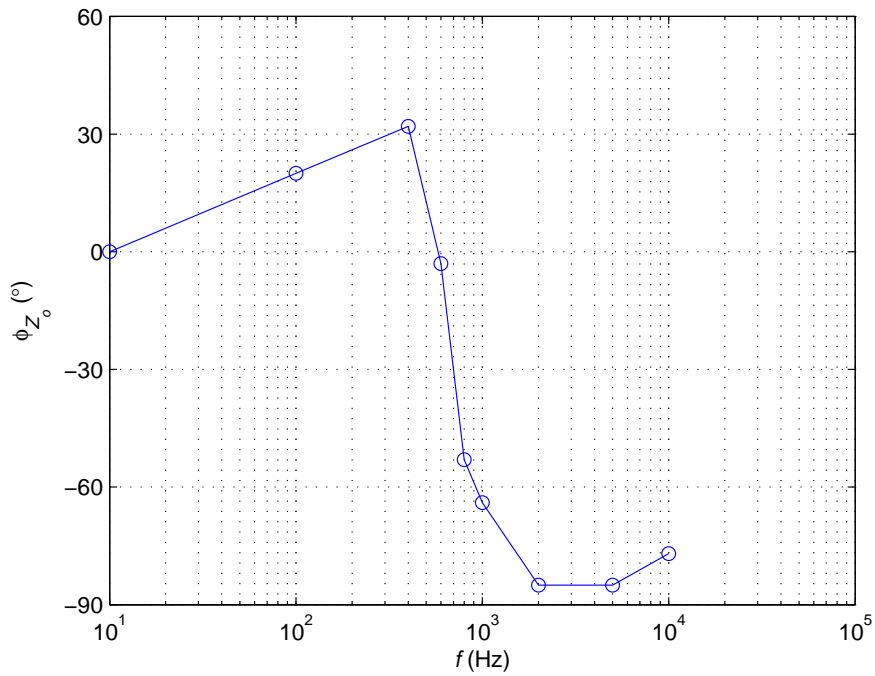

Figure 2.21: Discrete points open-loop phase Bode plot of output impedance transfer function  $Z_o$  for a buck-boost

$$v_i(s) = L\{v_i(t)\} \quad (2.45)$$

where the step change in s-domain is

$$v_i(s) = \frac{\Delta V_I}{s} \quad (2.46)$$

Therefore the transient response due to a step change in  $v_i$  becomes

$$v_o(s) = \frac{v(s)}{s} \quad (2.47)$$

$$= \Delta V_I M_{vo} \frac{\omega_0^2}{\omega_{zn}} \frac{s + \omega_{zn}}{s(s^2 + 2\zeta\omega_0s + \omega_0^2)} = \Delta V_I M_{vx} \frac{s + \omega_{zn}}{s(s^2 + 2\zeta\omega_0s + \omega_0^2)} \quad (2.48)$$

Returning from s-domain to time domain

$$v_o(t) = L\{v_o(s)\} \quad (2.49)$$

producing the magnitude of the transient response is

$$= \Delta V_I M_{vo} \left[ 1 + \sqrt{1 - \frac{2\zeta\omega_0}{\omega_{zn}} + \left(\frac{\omega_0}{\omega_{zn}}\right)^2} \frac{e^{-\sigma t}}{\sqrt{1 - \zeta^2}} \sin(\omega_d t + \phi) \right] \quad (2.50)$$

Where

$$\phi = \tan^{-1} \left[ \frac{\omega_d}{\omega_{zn} \left(1 - \frac{\zeta\omega_0}{\omega_{zn}}\right)} \right] + \tan^{-1} \left( \frac{\sqrt{1 - \zeta^2}}{\zeta} \right) \quad (2.51)$$

The total output voltage response is

$$v_o(t) = V(0^-) + v_o(t) \quad t \geq 0 \quad (2.52)$$

The maximum overshoot defined in equation where  $v_o(\infty)$  is the steady state value of the output voltage.

$$S_{max} = \frac{v_{omax} - v_o(\infty)}{v_o(\infty)} \quad (2.53)$$

Obtaining the derivative for equation and setting it equal to zero produces the time instants at which the maximum of  $v_o$  occurs

$$v_{omax} = \Delta V_I M_{v_o} \left[ 1 + \sqrt{1 - \frac{2\zeta \omega_o}{\omega_{zn}} + \left(\frac{\omega_o}{\omega_{zn}}\right)^2} \frac{e^{-\pi\zeta}}{\sqrt{1 - \zeta^2}} \right] \quad (2.54)$$

Therefore the maximum overshoot is

$$S_{max} = \sqrt{1 - \frac{2\zeta \omega_o}{\omega_{zn}} + \left(\frac{\omega_o}{\omega_{zn}}\right)^2} \frac{e^{-\pi\zeta}}{\sqrt{1 - \zeta^2}} \quad (2.55)$$

The maximum relative transient ripple of the total output voltage can be defined as

$$\delta_{max} = \frac{v_{omax} - v_o(\infty)}{v_o(\infty)} \quad (2.56)$$

where  $v_o(\infty)$  is defined as the steady state value of the output voltage. Given the measured values of the circuit are:  $V_I = 48 \text{ V}$ ,  $D = 0.407$ ,  $V_F = 0.7 \text{ V}$ ,  $r_{DS} = .4 \text{ } \Omega$ ,  $R_F = 0.02 \text{ } \Omega$ ,  $L = 334 \text{ mH}$ ,  $C = 68 \text{ } \mu\text{F}$ ,  $r_C = 0.033 \text{ } \Omega$ , and  $R_L = 14 \text{ } \Omega$ . These values lead to a maximum overshoot ,  $S_{max} = 35.67\%$  and a relative transient ripple  $\delta_{max} = 1.05\%$ .

The step change due to  $v_i$  is shown in Fig: 2.22 .

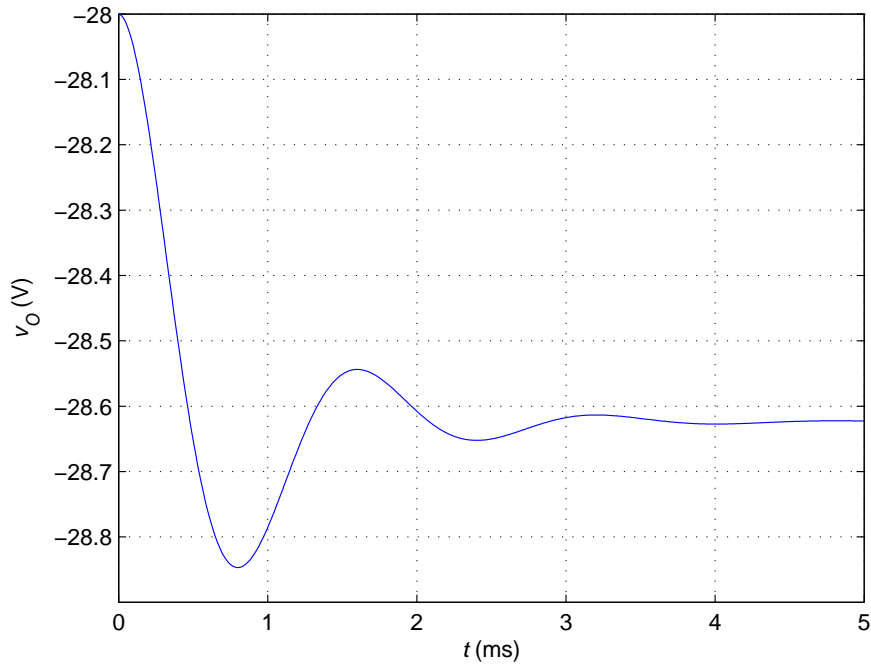

Figure 2.22: Open-Loop step response due to step change in input voltage  $v_i$ .

## 2.2.2 Open-Loop Response due to Load Current Step Change

Response of  $v_o$  due to a step change of .1 Amp in  $i_o$ . The total load current is given by equation 3.40 where  $u(t)$  is the unit step function and  $I_o(0^-)$  is the input current before applying the step current.

$$I_o(t) = I_o(0^-) + \Delta I_o u(t) \quad (2.57)$$

Step change in the time domain is

$$i_o(t) = i_o(t) - I_o(0^-) = \Delta I_o u(t) \quad (2.58)$$

Changing from time domain into s-domain the step change becomes

$$i_o(s) = \frac{\Delta I_o}{s} \quad (2.59)$$

The transient component of the output voltage is

$$\begin{aligned} v_o(s) &= Z_o(s)i_o(s) = -\frac{\Delta I_o R_L r_C}{R_L + r_C} \frac{(s + \omega_{zn})(s + \omega_{rl})}{s(s^2 + 2\zeta\omega_o s + \omega_o^2)} \\ &= -\Delta I_o Z_{ox} \frac{(s + \omega_{zn})(s + \omega_{rl})}{s(s^2 + 2\zeta\omega_o s + \omega_o^2)} \end{aligned} \quad (2.60)$$

Switching back from s-domain to time domain

$$v_o(t) = L^{-1}\{v_o(s)\} \quad (2.61)$$

The total output voltage is

$$v_o(t) = V(0^-) + v_o(t) \quad (2.62)$$

Again, the maximum relative transient ripple of the total output voltage can be defined as

$$\delta_{max} = \frac{v_{omax} - v_{o(\infty)}}{v_{o(\infty)}}$$

where  $v_{omax}$  is the steady state value of the total output voltage. Given the measured values of the circuit are:  $V_I = 48$  V,  $D = 0.407$ ,  $V_F = 0.7$  V,  $r_{DS} = 0.4$   $\Omega$ ,  $R_F = 0.02$   $\Omega$ ,  $L = 334$  mH,  $C = 68$   $\mu$ F,  $r_C = 0.033$   $\Omega$ , and  $R_L = 14$   $\Omega$ . These values lead to a maximum overshoot,  $S_{max} = 155.75\%$  and a relative transient ripple  $\delta_{max} = 0.708\%$ . The step change due to  $i_o$  is shown in Fig: 2.23.

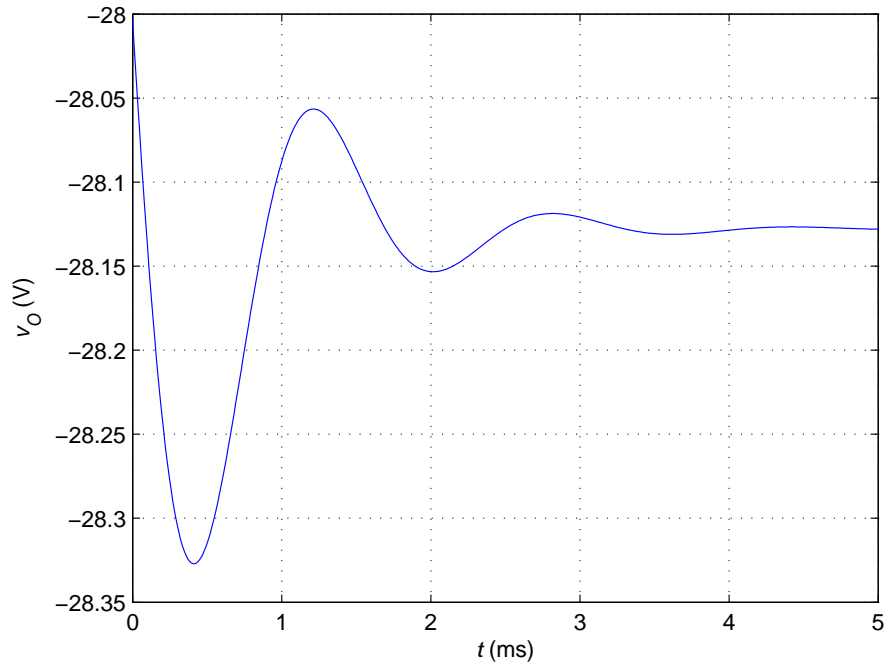

Figure 2.23: Open-Loop step response due to step change in load current  $i_o$ .

### 2.2.3 Open-Loop Response due to Duty Cycle Step Change

The step response of  $v_o$  for a step change of 0.1 in  $d$  is given. The total duty cycle is given by equation 3.40 where  $u(t)$  is the unit step function and  $D$  is the duty cycle before applying the step change in the duty cycle.

$$d_T(t) = D + \Delta d_T u(t) \quad (2.63)$$

The time domain step change in the duty cycle is

$$d(t) = d_T(t) - D = \Delta d_T u(t) \quad (2.64)$$

leading to the s-domain version which is

$$d(s) = \frac{\Delta d_T}{s} \quad (2.65)$$

The transient response of the output voltage of the open-loop buck-boost in s-domain is

$$\begin{aligned} v_o(s) &= T_p(s)d(s) = \frac{\Delta d_T T_p(s)}{s} \\ &= -\Delta d_T T_{po} \frac{\omega_o^2}{\omega_{zn} \omega_{zp}} \frac{(s + \omega_{zn})(s - \omega_{zp})}{s(s^2 + 2\zeta \omega_o s + \omega_o^2)} \end{aligned} \quad (2.66)$$

Switching back from s-domain to time domain

$$v_o(t) = L^{-1}\{v_o(s)\}$$

The total output voltage is

$$v_o(t) = V(0^-) + v_o(t)$$

Again, the maximum relative transient ripple of the total output voltage can be defined as

$$\delta_{max} = \frac{v_{omax} - v_{o(\infty)}}{v_{o(\infty)}}$$

where  $v_{omax}$  is the steady state value of the total output voltage. Given the measured values of the circuit are:  $V_I = 48$  V,  $D = 0.407$ ,  $V_F = 0.7$  V,  $r_{DS} = 0.4$   $\Omega$ ,  $R_F = 0.02$   $\Omega$ ,  $L = 334$  mH,  $C = 68$   $\mu$ F,  $r_C = .033$   $\Omega$ , and  $R_L = 14$   $\Omega$ . These values lead to a maximum overshoot,  $S_{max} = 36.01$  % and a relative transient ripple  $\delta_{max} = 10.16$  %. The step change due to  $d$  is shown in Fig: 2.24 .

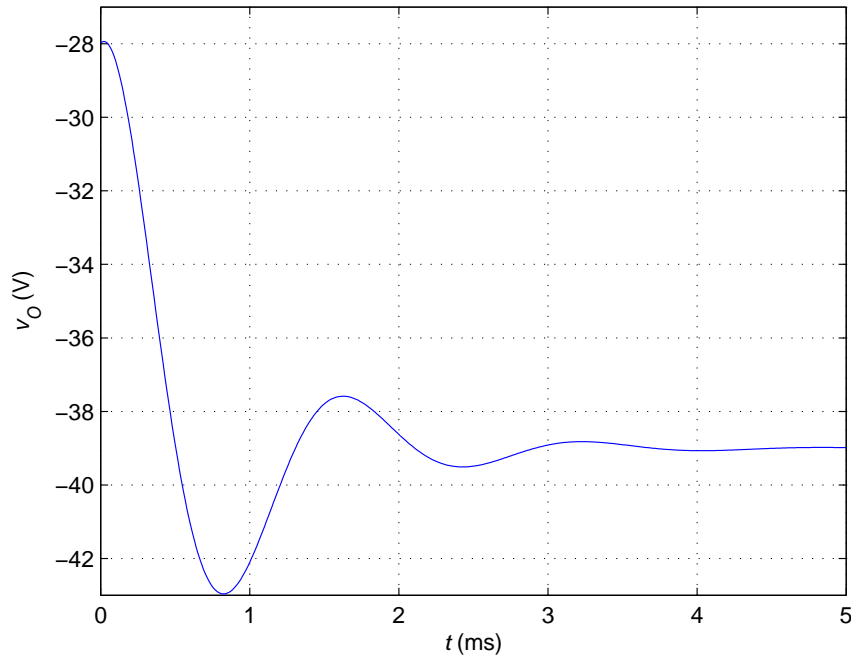

Figure 2.24: Open-Loop step response due to step change in duty cycle  $d$ .

## 2.3 Open-Loop Responses of Buck-Boost Using PSpice

### 2.3.1 Open-Loop Response of Buck-Boost

A circuit showing the open-loop buck-boost is shown in Fig 2.25 and a model of this circuit is shown in Fig 2.1. The measured values of the circuit are:  $V_I = 48 \text{ V}$ ,  $D = 0.389$ ,  $L = 334 \text{ mH}$ ,  $C = 68 \mu\text{F}$ ,  $r_C = 0.033 \Omega$ ,  $r_L = 0.32 \Omega$  and  $R_L = 14 \Omega$ . An International Rectifier IRF150 power MOSFET is selected, which has a  $V_{DSS} = 100 \text{ V}$ ,  $I_{SM} = 40 \text{ A}$ ,  $r_{DS} = 55 \text{ m}\Omega$ ,  $C_o = 100 \text{ pF}$ , and  $Q_g = 63 \text{ nC}$ . Also, an International Rectifier 10CTQ150 Schottky Common Cathode Diode is selected with a  $V_R = 100 \text{ V}$ ,  $I_{F(AV)} = 10 \text{ A}$ ,  $V_F = 0.73 \text{ V}$  and  $R_F = 28 \text{ m}\Omega$ . The duty cycle for the MOSFET changes from 0.407 to 0.389 to obtain the correct output of  $-28 \text{ V}$  as predicted using MatLab. Also the switching frequency for  $V_p$  which controls the duty cycle is 100kHz

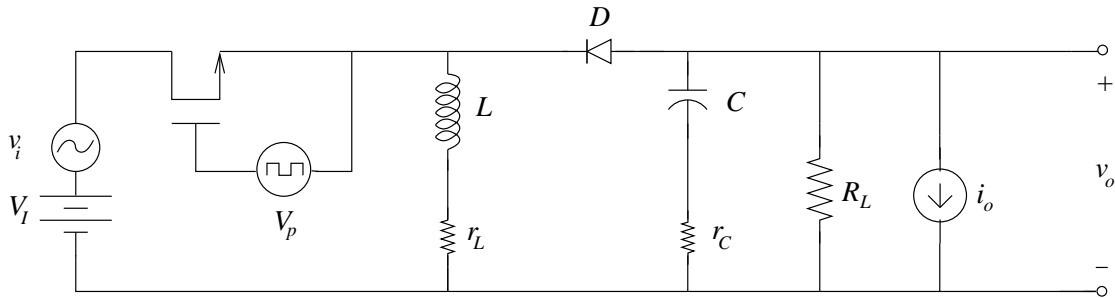

Figure 2.25: Open-loop buck-boost model with disturbances.

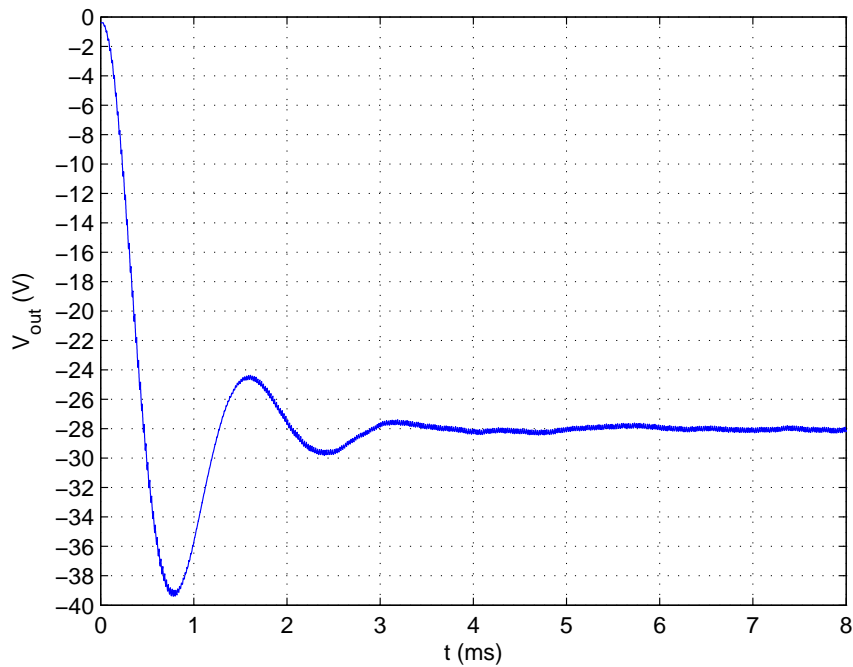

Figure 2.26: Open-loop buck-boost response without disturbances.

allowing for a fast response time. The disturbances to the system are  $v_i$ ,  $i_o$  and  $d$ .

The output voltage of the buck-boost without any disturbances can be seen in Fig 2.26 . The maximum overshoot is 41.25 %, settling time within five percent of steady state value is 3ms, and settling time withing one percent of steady state value is 7ms.

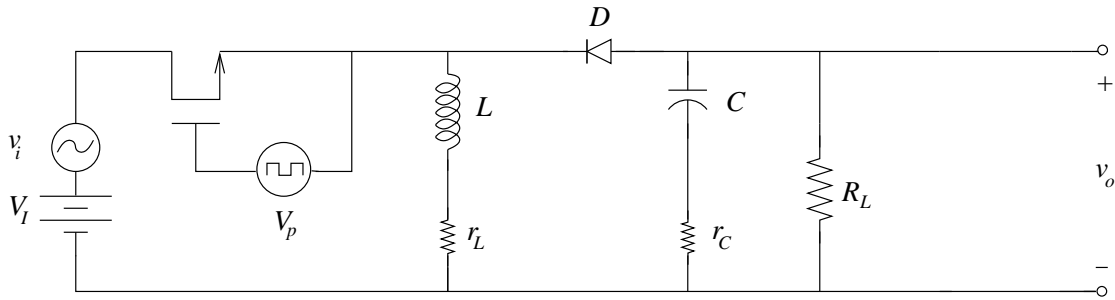

Figure 2.27: PSpice model of Open-Loop buck-boost with step change in input voltage.

### 2.3.2 Open-Loop Response due to Input Voltage Step Change

The PSpice circuit with step change in input voltage is shown in Fig 2.27. An additional voltage pulse source of 1 volt was added with a delay of 10 ms, so that the circuit ran for sufficient time to reach steady state value, and then the disturbance is activated. The output voltage of the buck boost can be seen in Fig 2.28. The voltage ripple is .22 volts contained between  $-27.33\text{ V}$  and  $-27.55\text{ V}$ , the average value of steady state is  $-27.425\text{ V}$ . The maximum overshoot is  $S_{max} = 21.74\%$  and settling time within one percent is 2ms which contains the ripple of steady state value. The relative maximum overshoot is  $\delta_{max} = 0.455\%$ .

### 2.3.3 Open-Loop Response due to Load Current Step Change

The PSpice circuit with step change in load current is shown in Fig 2.29. An additional current pulse source of .1 Amp was added with a delay of 10 ms so that the circuit ran for sufficient time to reach steady state value, then the disturbance is activated. The output voltage of the buck boost can be seen in Fig 2.30 . The voltage ripple is 0.22 V and the output voltage is contained between  $-28.36\text{ V}$  and  $-28.14\text{ V}$ . the average value of steady state is  $-22.25\text{ V}$  . The maximum overshoot is  $S_{max} = 88\%$  and settling time within one percent is 1.4ms which contains the ripple of steady state value. The relative maximum overshoot is  $\delta_{max} = 0.779\%$ .

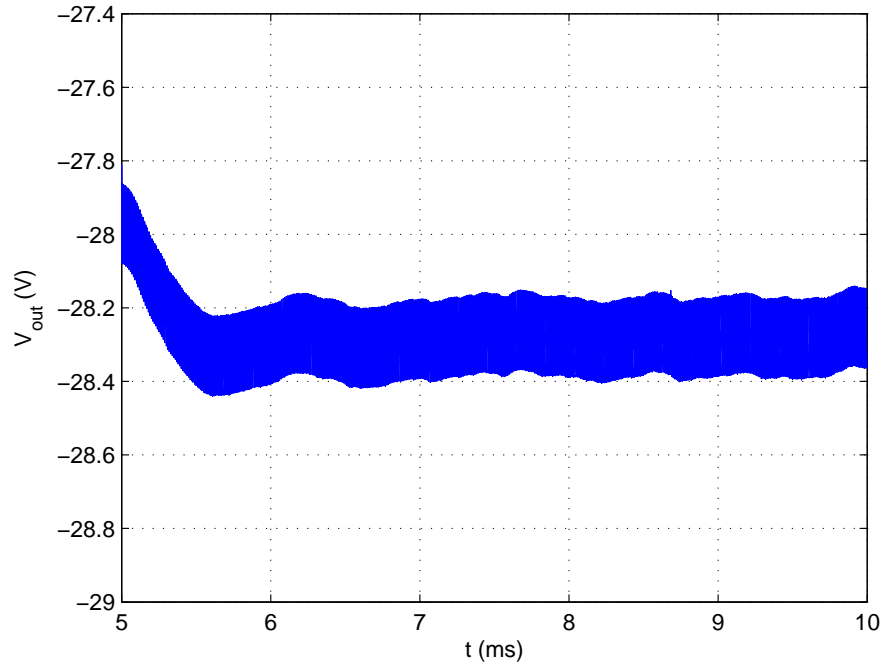

Figure 2.28: Open-Loop step response due to step change in input voltage using PSpice.

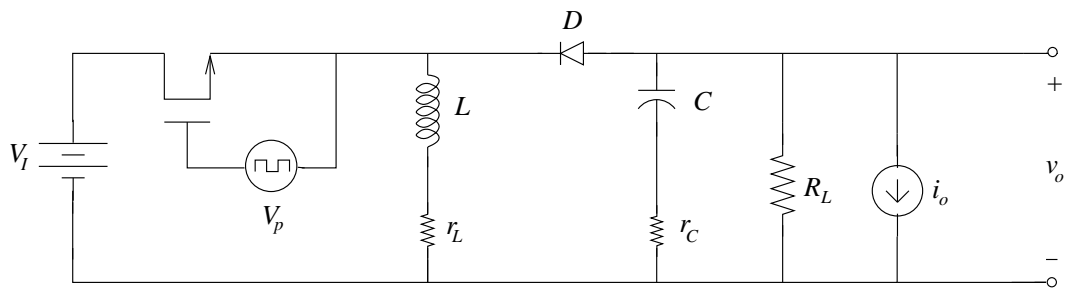

Figure 2.29: PSpice model of Open-Loop buck-boost with step change in load current.

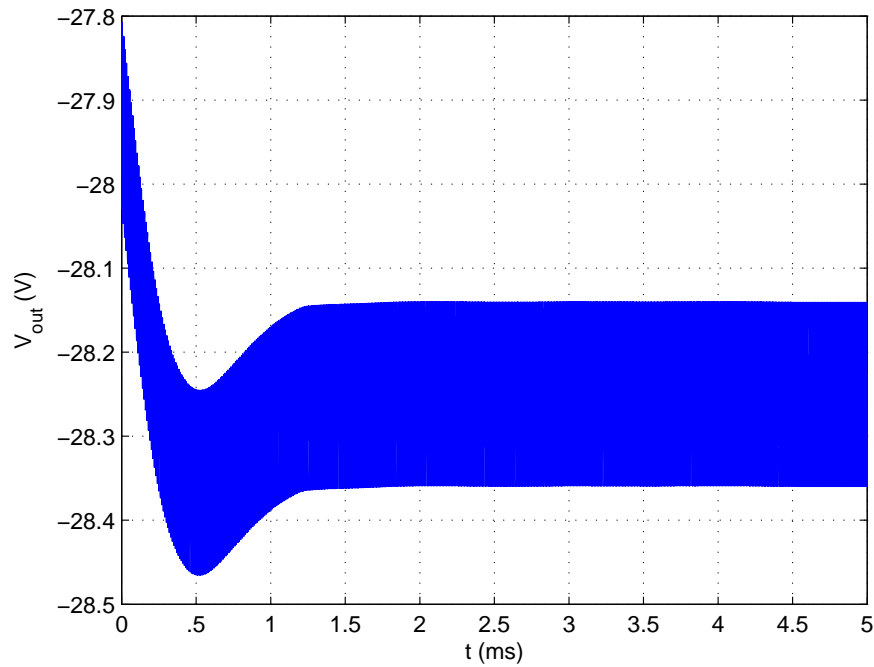

Figure 2.30: Open-Loop step response due to step change in load current using PSpice.

### 2.3.4 Open-Loop Response due to Duty Cycle Step Change

The PSpice circuit with step change in duty cycle is shown in Fig 2.31. An addition voltage pulse source is added with a switch now on both Pulse generators. The first pulse generator has its switch closed and running for the first ten ms so that it can achieve the desired steady state value then simultaneously the switch to  $V_p$  is opened and the switch to  $V_{p2}$  is closed with the new duty cycle increased by 0.1. The output voltage of the buck boost can be seen in Fig 2.32 . The voltage ripple is 0.34 V the average voltage of steady state is  $-34.03$  V and the output voltage is contained between the bounds of  $-33.86$  V and  $-34.2$  V . The settling time is within one percent, which contains the ripple, of steady state value is 2.5 ms.

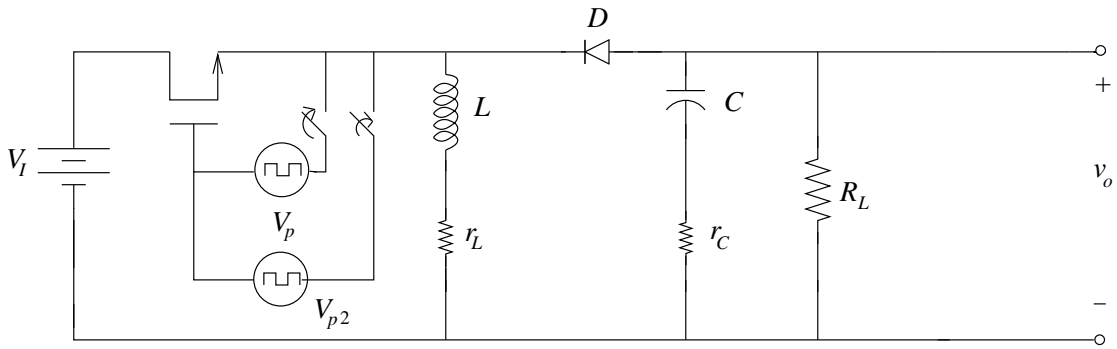

Figure 2.31: PSpice model of Open-Loop buck-boost with step change in duty cycle.

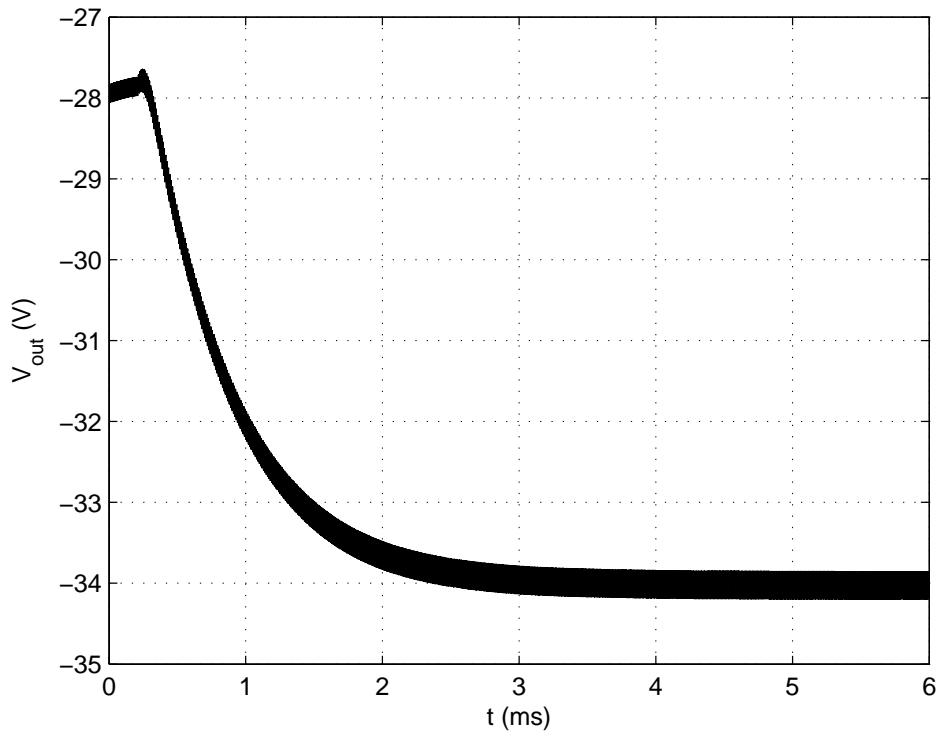

Figure 2.32: Open-Loop step response due to step change in duty cycle using PSpice.

## 3 Closed Loop Response

### 3.1 Closed Loop Transfer Functions

Fig 3.1 shows the power stage of a buck-boost converter circuit with single-loop control circuit. The control circuit is a single-loop voltage mode control. A small-signal closed-loop model of the buck-boost is shown in Fig 3.2.

A block diagram of the closed-loop buck-boost is shown in Fig 3.3.  $v_r$ ,  $v_e$ ,  $v_c$  and  $v_f$  are all ac components of the reference voltage, error voltage, output voltage of controller and feedback voltage respectively.  $T_p$  is the small-signal control to output transfer function of the non-controlled buck-boost.  $M_v$  is the open-loop input to output voltage transfer function.  $Z_o$  is the open-loop output impedance.  $T_m$  is the transfer function of the pulse width modulator (PWM). The function is the inverse of the hieght of the ramp voltage being sent to the second op-amp which is being used as a comparator.  $T_c$  is the transfer function for the lead-intergral controller and  $T$  is the loop gain. The circuit is one control input and two disturbances and one output where the independent inputs are  $v_r$ ,  $v_i$ , and  $i_o$  respectively and the output is  $v_o$ . The output voltage is expressed in transfer functions as

$$v_o(s) = \frac{T_c T_m T_p}{1 + \beta T_c T_m T_p} v_r + \frac{M_v}{1 + \beta T_c T_m T_p} v_i - \frac{Z_o}{1 + \beta T_c T_m T_p} i_o$$

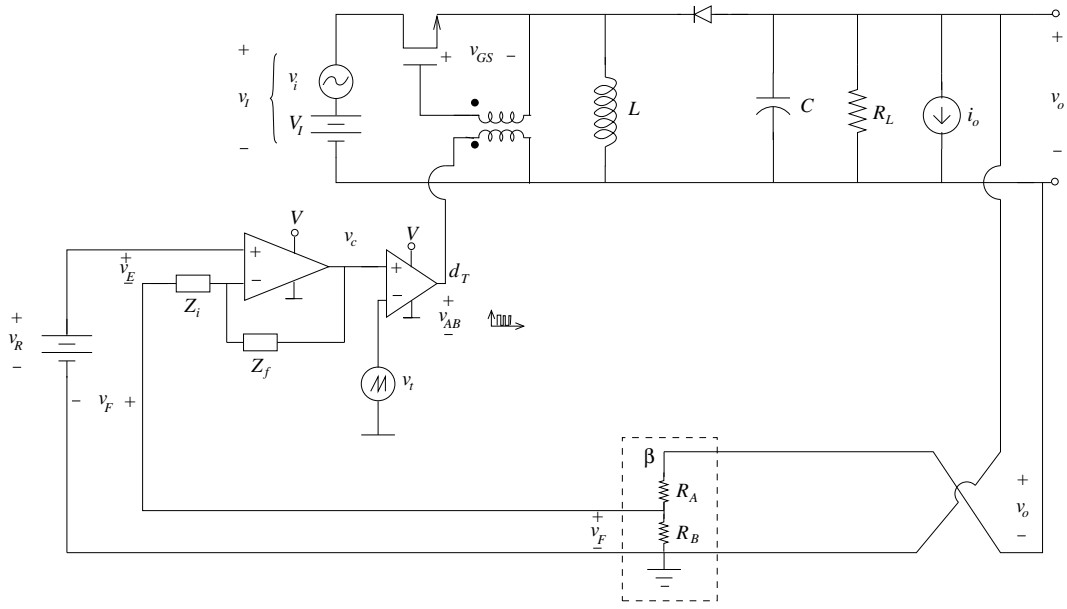

Figure 3.1: Closed loop circuit of voltage controlled buck-boost with PWM.

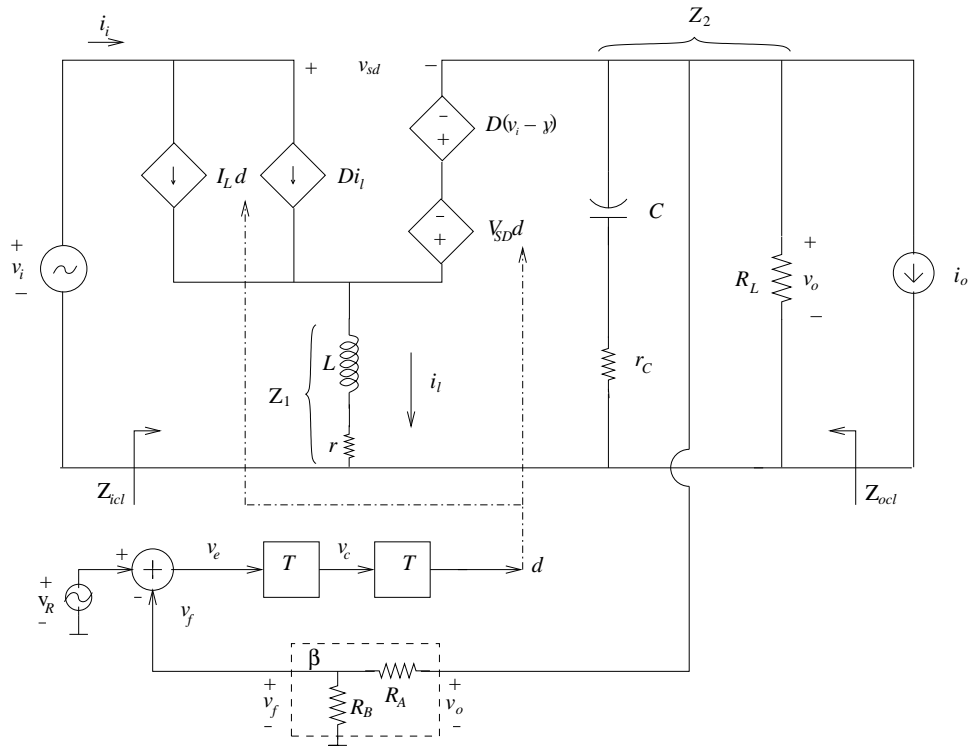

Figure 3.2: Closed loop small-signal model of voltage controlled buck-boost.

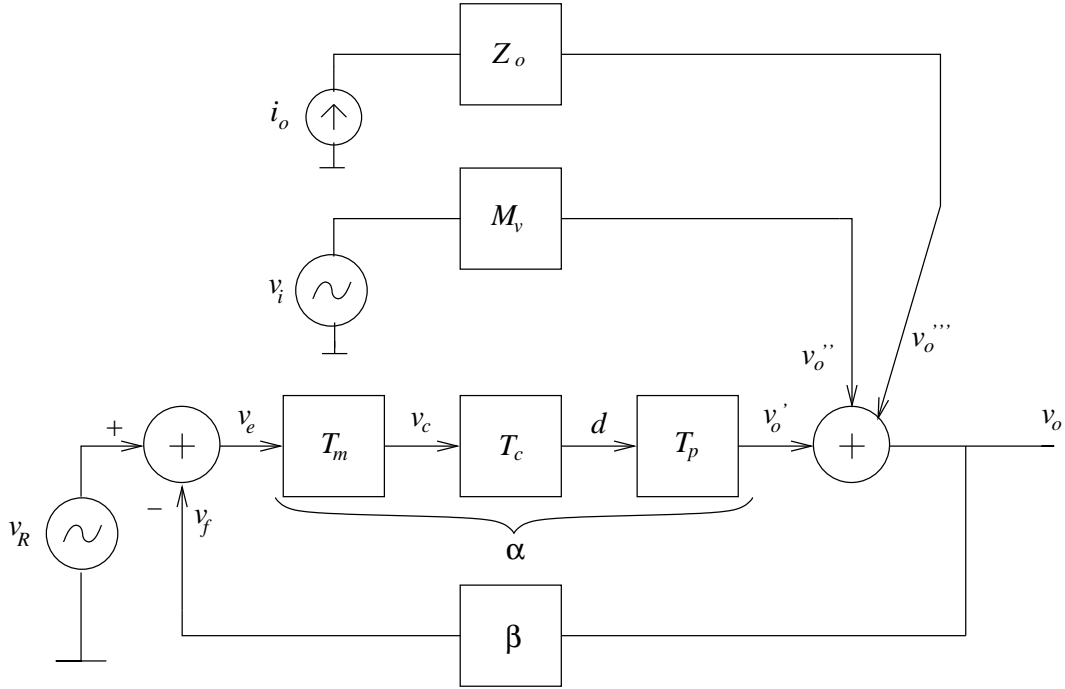

Figure 3.3: Block diagram of a closed-loop small-signal voltage controlled buck-boost.

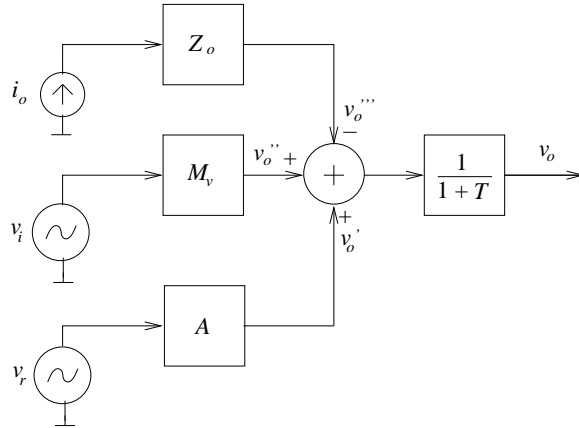

Figure 3.4: Simplified block diagram of a closed-loop small-signal voltage controlled buck-boost.

$$= \frac{A}{1+T}v_r + \frac{M_v}{1+T}v_i - \frac{Z_o}{1+T}i_o = T_{cl}v_r + M_{vcl}v_i - Z_{ocl}i_o \quad (3.1)$$

Where  $A = T_c T_m T_p$  and  $T = \beta A$

PWM transfer function is expressed

$$T_m \equiv \frac{d(s)}{v_c(s)} = \frac{1}{V_{Tm}} \quad (3.2)$$

Where  $V_{Tm}$  is peak value of the triangular pulse.

Combining  $T_m$  and  $T_p$  together, the control to output transfer function is produced giving a new function  $T_{mp}$ , given by

$$T_{mp}(s) = T_m(s)T_p(s) = \frac{v_o r_C}{V_{Tm}(1-D)(R_L + r_C)} \frac{(s + \omega_{zn})(s - \omega_{zp})}{s^2 + 2\zeta\omega_o s + \omega_o^2} \quad (3.3)$$

$$T_{mpx} = \frac{v_o r_C}{V_{Tm}(1-D)(R_L + r_C)} \quad (3.4)$$

$$T_{mpo} = T_m T_{po} = \frac{T_{po}}{V_{Tm}} = \frac{v_o r_C \omega_{zn} \omega_{zp}}{V_{Tm}(1-D)(R_L + r_C) \omega_o^2} \quad (3.5)$$

Figs: 3.5 and 3.6 show the Bode plots of  $T_{mp}$ .

To find the compensator value find  $T_k$

$$\begin{aligned} T_k &\equiv \frac{v_f}{v_c} \Big|_{v_i=0} = \beta T_m T_p = \beta T_{mp} \\ &= -\frac{\beta v_o r_C}{V_{Tm}(1-D)(R_L + r_C)} \frac{(s + \omega_{zn})(s + \omega_{zp})}{s^2 + 2\zeta\omega_o s + \omega_o^2} \end{aligned} \quad (3.6)$$

$$T_{kx} = \frac{\beta v_o r_C}{V_{Tm}(1-D)(R_L + r_C)} \quad (3.7)$$

$$T_{ko} = \frac{\beta v_o r_C \omega_{zn} \omega_{zp}}{V_{Tm}(1-D)(R_L + r_C) \omega_o^2} \quad (3.8)$$

Changing from s-domain into  $j\omega$  domain gives

$$|T_k| = T_{ko} \frac{\sqrt{1 + \left(\frac{f}{f_{zn}}\right)^2} \sqrt{1 + \left(\frac{f}{f_{zp}}\right)^2}}{\sqrt{\left(1 + \left(\frac{f}{f_o}\right)^2\right)^2 + \left(\frac{2\zeta f}{f_o}\right)^2}} \quad (3.9)$$

$$\phi_{T_k} = \tan^{-1}\left(\frac{f}{f_{zn}}\right) - \tan^{-1}\left(\frac{f}{f_{zp}}\right) - \tan^{-1}\left(\frac{\left(\frac{2\zeta f}{f_o}\right)}{1 - \left(\frac{f}{f_o}\right)^2}\right) \text{ when } \frac{f}{f_o} < 1, \quad (3.10)$$

$$\phi_{T_k} = -180^\circ + \tan^{-1}\left(\frac{f}{f_{zn}}\right) - \tan^{-1}\left(\frac{f}{f_{zp}}\right) - \tan^{-1}\left(\frac{\left(\frac{2\zeta f}{f_o}\right)}{1 - \left(\frac{f}{f_o}\right)^2}\right) \text{ when } \frac{f}{f_o} > 1. \quad (3.11)$$

Figs: 3.7 and 3.8 show the Bode plots of  $T_k$ .

### 3.1.1 Integral-Lead Control Circuit for Buck-Boost

The following reasons explain the need for a control circuit in dc-dc power converters:

1. To achieve a sufficient degree of relative stability, an acceptable gain between 6 to 12 dB and phase margins between  $45^\circ$  and  $90^\circ$ .
2. To reduce dc error.
3. To achieve a wider bandwidth and fast transient response.
4. To reduce the output impedance  $Z_{ocl}$ .
5. To reduce sensitivity of the closed-loop gain  $T_{cl}$  to component values over a wide frequency range.
6. To reduce the input to output noise transmission.

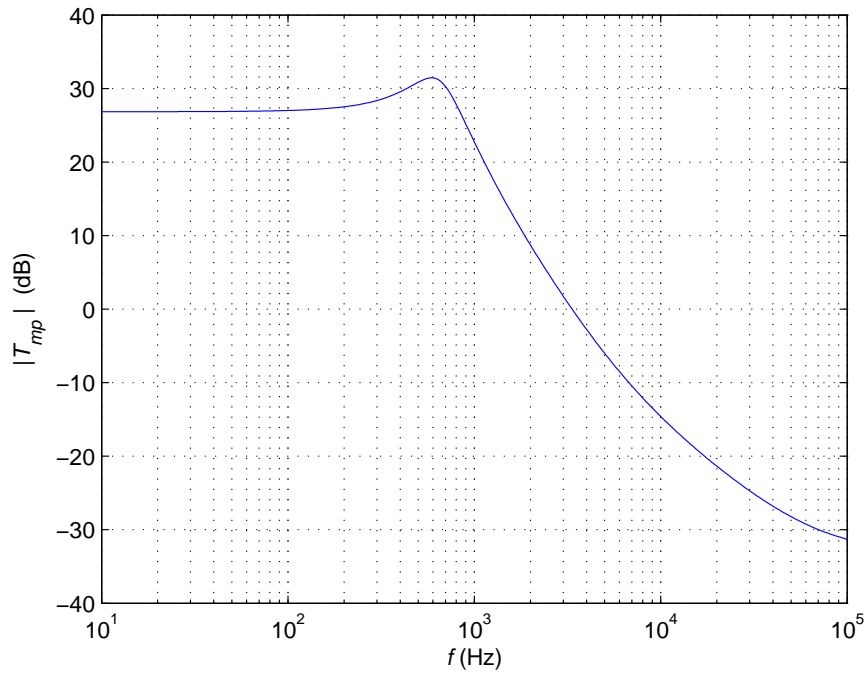

Figure 3.5: Magnitude Bode plot of modulator and input control to output voltage transfer function  $T_{mp}$  for a buck-boost.

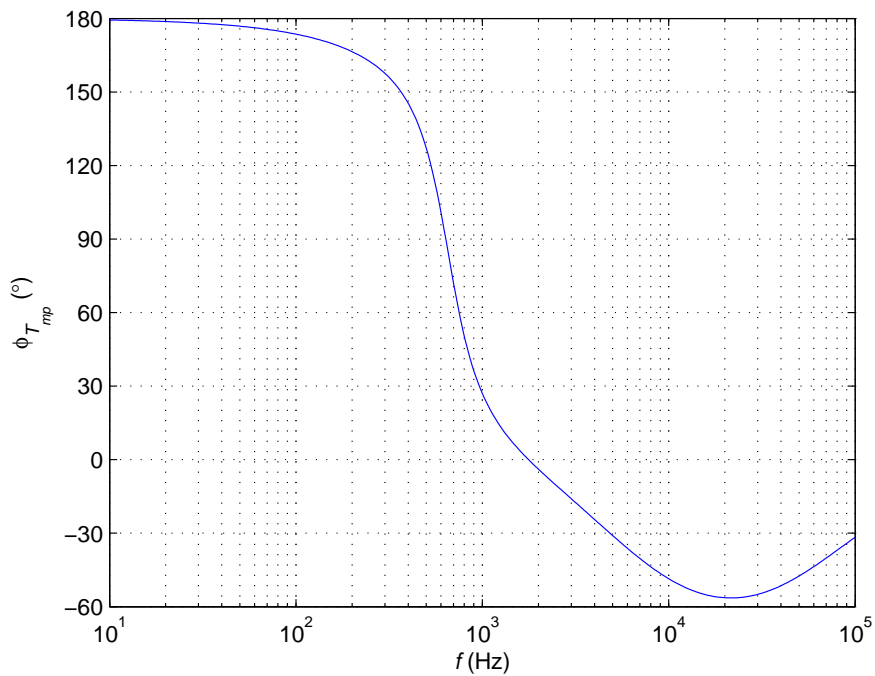

Figure 3.6: Phase Bode plot of modulator and input control to output voltage transfer function  $T_{mp}$  for a buck-boost.

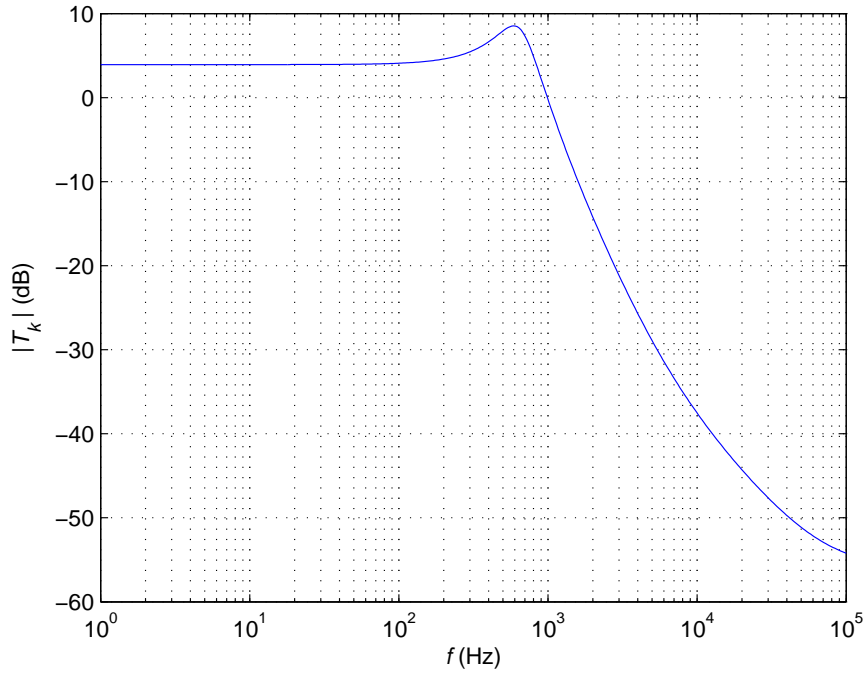

Figure 3.7: Magnitude Bode plot of the input control to output voltage transfer function  $T_k$  before the compensator is added for a buck-boost.

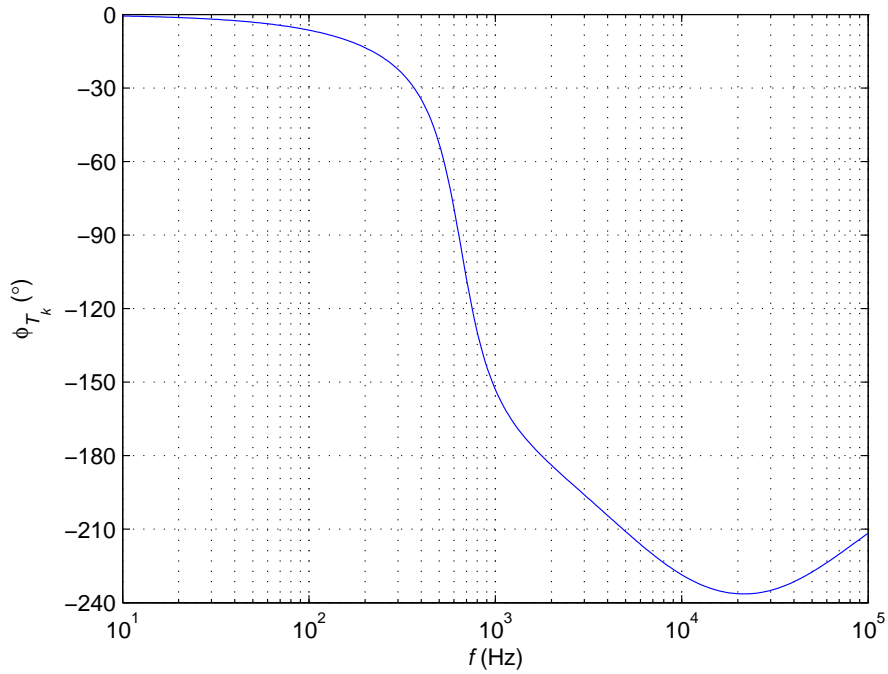

Figure 3.8: Phase Bode plot of the input control to output voltage transfer function  $T_k$  before the compensator is added for a buck-boost.

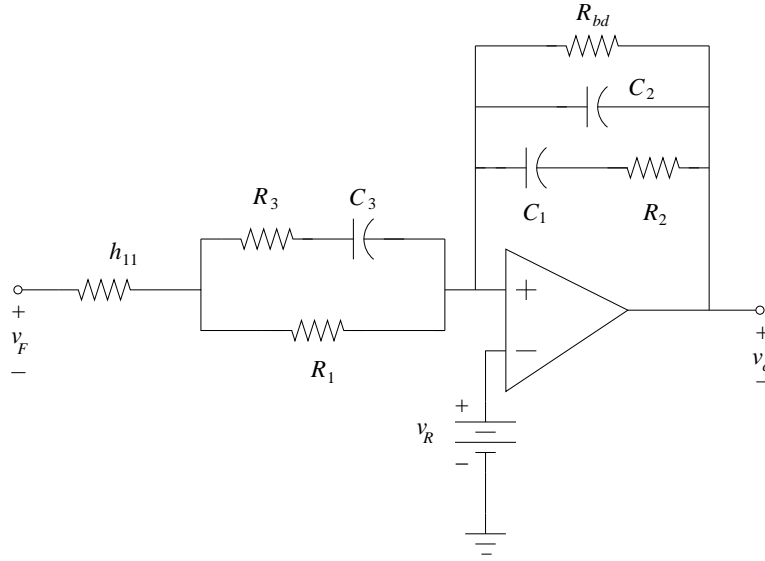

Figure 3.9: The Integral Lead Controller

Fig 3.9 shows the integral-lead controller that was chosen. This controller was chosen because the integral part of the controller allows for high gain at low frequencies but introduces a  $-90^\circ$  phase shift at all frequencies. This causes stability issues which is negated by the lead part of the controller that compensates for the phase lag and more. Theoretically it should introduce a  $180^\circ$  phase lead but practically produces a shift of between  $150^\circ$  and  $160^\circ$ . The impedances of the amplifier are

$$\begin{aligned}
 Z_i &= h_{11} + \frac{R_1 \left( R_3 + \frac{1}{sC_3} \right)}{R_1 + R_3 + \frac{1}{sC_3}} \\
 &= \frac{h_{11} \left( R_1 + R_3 + \frac{1}{sC_3} \right) + R_1 \left( R_3 + \frac{1}{sC_3} \right)}{R_1 + R_3 + \frac{1}{sC_3}} \\
 &= \frac{sC_3 h_{11} R_1 + sC_3 h_{11} R_3 + h_{11} + R_1 R_3 sC_3 + R_1}{sC_3 R_1 + sC_3 R_3 + 1} \\
 &= \frac{C_3 (h_{11} (R_1 + R_3) + R_1 R_3)}{C_3 (R_1 + R_3)} s + \frac{h_{11} + R_1}{C_3 (h_{11} (R_1 + R_3) + R_1 R_3)} \\
 &= \frac{C_3 (h_{11} (R_1 + R_3) + R_1 R_3)}{C_3 (R_1 + R_3)} s + \frac{1}{C_3 (R_1 + R_3)}
 \end{aligned}$$

$$= \left( h_{11} + \frac{R_1 R_3}{(R_1 + R_3)} \right) \frac{s + \frac{h_{11} + R_1}{C_3(h_{11}(R_1 + R_3) + R_1 R_3)}}{s + \frac{1}{C_3(R_1 + R_3)}} \quad (3.12)$$

$$\begin{aligned} Z_f &= \frac{\frac{1}{sC_2} \left( R_2 + \frac{1}{sC_1} \right)}{R_2 + \frac{1}{sC_1} + \frac{1}{sC_2}} = \frac{\frac{1}{sC_2} R_2 + \frac{1}{C_1 C_2 s^2}}{R_2 + \frac{1}{sC_1} + \frac{1}{sC_2}} \\ &= \frac{1}{C_2} \frac{\left( s + \frac{1}{R_2 C_2} \right)}{s \left( s + \frac{C_1 + C_2}{R_2 C_1 C_2} \right)} \end{aligned} \quad (3.13)$$

and

$$h_{11} = \frac{R_A R_B}{R_A + R_B}.$$

Assume infinite open-loop dc gain and open-loop bandwidth of the operational amplifier.

Therefore, from equations 3.12 and 3.13, the voltage transfer function of the amplifier is

$$\begin{aligned} A_v(s) &\equiv \frac{v_c(s)}{v_f(s)} = -\frac{Z_f}{Z_i} = \frac{\frac{1}{C_2}}{h_{11} + \frac{R_1 R_2}{R_1 + R_2}} \left( \frac{\frac{\left( s + \frac{1}{R_2 C_2} \right)}{s \left( s + \frac{C_1 + C_2}{R_2 C_1 C_2} \right)}}{\frac{s + \frac{h_{11} + R_1}{C_3(h_{11}(R_1 + R_3) + R_1 R_3)}}{s + \frac{1}{C_3(R_1 + R_3)}}}} \right) \\ &= \frac{R_1 + R_3}{C_2(h_{11}(R_1 + R_3) + R_1 R_3)} \left( \frac{\left( s + \frac{1}{R_2 C_2} \right) \left( s + \frac{1}{C_3(R_1 + R_3)} \right)}{s \left( s + \frac{C_1 + C_2}{R_2 C_1 C_2} \right) \left( s + \frac{h_{11} + R_1}{C_3(h_{11}(R_1 + R_3) + R_1 R_3)} \right)} \right) \end{aligned} \quad (3.14)$$

Because  $v_r = 0$ ,  $v_e = v_r - v_f = -v_f$ , the voltage transfer function of the integral lead controller is

$$T_c \equiv \frac{v_c}{v_e} = -\frac{v_c(s)}{v_f(s)} = B \frac{(s + \omega_{zc1})(s + \omega_{zc2})}{s(s + \omega_{pc1})(s + \omega_{pc2})} \quad (3.15)$$

where

$$B = \frac{R_1 + R_3}{C_2(h_{11}(R_1 + R_3) + R_1 R_3)}$$

$$\omega_{zc1} = \left( s + \frac{1}{R_2 C_2} \right)$$

$$\omega_{zc2} = \left( s + \frac{1}{C_3(R_1 + R_3)} \right)$$

$$\omega_{pc1} = \left( s + \frac{C_1 + C_2}{R_2 C_1 C_2} \right)$$

$$\omega_{pc2} = \left( s + \frac{h_{11} + R_1}{C_3(h_{11}(R_1 + R_3) + R_1 R_3)} \right)$$

Assume that  $\omega_{zc1} = \omega_{zc2} = \omega_{zc}$  and  $\omega_{pc1} = \omega_{pc2} = \omega_{pc}$ . Therefore

$$\begin{aligned} K &= \frac{\omega_{pc1}}{\omega_{zc1}} = \frac{\omega_{pc2}}{\omega_{zc2}} = \frac{\omega_{pc}}{\omega_{zc}} \\ &= \frac{\frac{C_1 + C_2}{R_2 C_1 C_2}}{\frac{1}{R_2 C_1}} = \frac{\frac{h_{11} + R_1}{C_3(h_{11}(R_1 + R_3) + R_1 R_3)}}{\frac{1}{C_3(R_1 + R_3)}} \\ &= \frac{(h_{11} + R_1)(R_1 + R_3)}{h_{11}(R_1 + R_3) + R_1 R_3} = 1 + \frac{C_2}{C_1} \end{aligned} \quad (3.16)$$

This leads to the voltage transfer function of the controller to be

$$T_c \equiv \frac{v_c}{v_e} = B \frac{(s + \omega_{zc})^2}{s(s + \omega_{pc})^2} = B \frac{(s + \omega_{zc})^2}{s(s + \omega_{pc})^2} = \frac{B(1 + \frac{s}{\omega_{zc}})^2}{K^2 s(1 + \frac{s}{\omega_{pc}})^2}$$

For  $s = j\omega$ , the magnitude and phase shift of  $T_c$  is

$$|T_c(j\omega)| = \frac{B(1 + \frac{\omega}{\omega_{zc}})^2}{K^2 s(1 + \frac{\omega}{\omega_{pc}})^2} = \frac{B}{\omega_m K} = \frac{1}{\omega_m C_2 (R_1 + h_{11})}$$

and

$$\phi_{T_c} = -\frac{\pi}{2} + 2 \tan^{-1} \left( \frac{\frac{\omega}{\omega_{zc}} - \frac{\omega}{\omega_{pc}}}{1 + \frac{\omega^2}{\omega_{zc}\omega_{pc}}} \right)$$

## Design of Integral Lead Controller

For stability reasons a gain margin  $GM \geq 9$  dB, a phase margin  $PM \geq 60^\circ$ , and the cutoff frequency  $f_c = 2$  kHz is chosen. The values of the buck-boost are  $V_I = 48$  V,  $D = 0.407$ ,  $V_F = 0.7$  V,  $r_{DS} = 0.4 \Omega$ ,  $R_F = 0.02 \Omega$ ,  $L = 334$  mH,  $C = 68 \mu\text{F}$ ,  $r_C = 0.033 \Omega$ , and  $R_L = 14 \Omega$ .

The maximum value of phase in  $T_c$  occurs

$$\omega_c = \omega_m = \sqrt{K}\omega_{zc} = \frac{\omega_{pc}}{\sqrt{K}} = \frac{\sqrt{K}}{R_2 C_1} = \frac{h_{11} + R_1}{\sqrt{K} C_3 (h_{11}(R_1 + R_3) + R_1 R_3)}$$

Therefore the maximum phase shift possible can be described by

$$\phi_m = \phi_{T_c}(f_m) + \frac{\pi}{2} = 2 \tan^{-1} \left( \frac{K-1}{2\sqrt{K}} \right)$$

Solving for K leads to

$$K = \frac{1 + \sin\left(\frac{\phi_m}{2}\right)}{1 - \sin\left(\frac{\phi_m}{2}\right)} = \tan^2 \left( \frac{\phi_m}{4} + \frac{\pi}{4} \right)$$

Therefore,

$$\phi_m = -\pi + 4 \tan^{-1}(\sqrt{K})$$

Assuming  $V_{Tm} = 5$  V, the reference voltage is

$$V_R = D_{nom} V_{Tm} = .407(5) = 2.035 \text{ V}$$

The feedback network transfer function  $\beta$  is

$$\beta = \frac{V_F}{V_o} = \frac{V_R}{V_o} = -\frac{R_A}{R_A + R_B} = -\frac{2}{28} = -0.0714$$

Assuming  $R_B = 910\Omega$ ,  $R_A$  is

$$R_A = R_B \left( \frac{1}{|\beta|} - 1 \right) = 910 \left( \frac{1}{.0714} - 1 \right) = 11.83 k\Omega = 12 k\Omega$$

If  $R_B = 910\Omega$ ,  $R_A = 12 k\Omega$  then

$$h_{11} = \frac{R_A R_B}{R_A + R_B} = 846 \Omega.$$

$h_{22}$  can be neglected because  $R_A + R_B$  is so much larger than  $R_L$ .

Utilizing the cutoff frequency  $f_c$  the phase  $\phi_{T_k}$  and  $\phi_m$  are

$$\phi_{T_k} = -180 + \tan^{-1} \left( \frac{f_c}{f_{zn}} \right) - \tan^{-1} \left( \frac{f_c}{f_{zp}} \right) - \tan^{-1} \left( \frac{\frac{2\zeta f_c}{f_o}}{1 - \left( \frac{f_c}{f_o} \right)^2} \right) = -183.9^\circ$$

and

$$\phi_m = PM - \phi_{T_k} - 90 = 153.9^\circ.$$

This leads to

$$K = \tan^2 \left( \frac{\phi_m}{4} + \frac{\pi}{4} \right) = 76.42.$$

Knowing  $K$ ,  $f_{zc}$  and  $f_{zp}$  are calculated

$$f_{zc} = \frac{f_c}{\sqrt{K}} = 228.779 \text{ Hz}$$

and

$$f_{zp} = f_c \sqrt{K} = 17.484 \text{ kHz}$$

The magnitude of  $T_k$  and  $T_c$  are used to calculate B

$$|T_k| = T_{ko} \frac{\sqrt{1 + \left(\frac{f_c}{f_{zn}}\right)^2} \sqrt{1 + \left(\frac{f_c}{f_{zp}}\right)^2}}{\sqrt{\left[1 - \left(\frac{f_c}{f_o}\right)^2\right]^2 + \left(\frac{2\zeta f_c}{f_o}\right)^2}} = 0.1945$$

$$|T_c| = \frac{1}{|T_k|} = \frac{1}{.1954} = 5.141$$

Therefore

$$B = \omega_c K |T_c| = 4.9374 \times 10^6 \text{ rad/s}$$

Values of compensator are calculated. Assume  $R_1 = 100 \text{ k}\Omega$  and using the equations above

$$C_2 = \frac{|T_k(f_c)|}{\omega_c (R_1 + h_{11})} = .1535 \text{ nF} \approx .15 \text{ nF.}$$

$$R_3 = \frac{R_1 [R_1 - h_{11}(K - 1)]}{(K - 1)(R_1 + h_{11})} = 475 \Omega \approx 470 \Omega$$

$$C_1 = C_2(K - 1) = 11.313 \text{ nF} \approx 12 \text{ nF}$$

$$R_2 = \frac{\sqrt{K}}{\omega_c C_1} = 57.97 \text{ k}\Omega \approx 56 \text{ k}\Omega$$

$$C_3 = \frac{R_1 + h_{11}}{\sqrt{K} \omega_c [R_1 R_3 + h_{11}(R_1 + R_3)]} = 6.95 \text{ nF} \approx 6.8 \text{ nF}$$

The pole and zero frequencies of the control circuit with standard resistor and capacitor values are

$$f_{zc1} = \frac{1}{2\pi R_2 C_1} = 236.84 \text{ Hz}$$

$$f_{zc2} = \frac{1}{2\pi C_3 (R_1 + R_3)} = 232.96 \text{ Hz}$$

$$f_{pc1} = f_{zc1} \left( \frac{C_1}{C_2} + 1 \right) = 19.184 \text{ kHz}$$

and

$$f_{pc2} = \frac{R_1 + h_{11}}{2\pi C_3 [R_1 R_3 + h_{11} (R_1 + R_3)]} = 17.881 \text{ kHz.}$$

Figs: 3.10 and 3.11 show the Bode plots of  $T_c$ .

### 3.1.2 Loop Gain of System

Loop gain of the system is

$$T(s) \equiv \frac{v_f}{v_e} \Big|_{v_i=i_o=0} = \beta T_c T_m T_p = T_c T_k$$

$$T(s) = -\frac{\beta B v_o r_C}{V_{Tm}(1-D)(R_L + r_C)} \left( \frac{(s + \omega_{zc})^2 (s + \omega_{zn})(s - \omega_{zp})}{s(s + \omega_{pc})^2 + 2\zeta \omega_o s + \omega_o^2} \right)$$

$$T(s) = T_x \left( \frac{(s + \omega_{zc})^2 (s + \omega_{zn})(s - \omega_{zp})}{s(s + \omega_{pc})^2 + 2\zeta \omega_o s + \omega_o^2} \right) \quad (3.17)$$

where

$$T_x = -\frac{\beta B v_o r_C}{V_{Tm}(1-D)(R_L + r_C)} \quad (3.18)$$

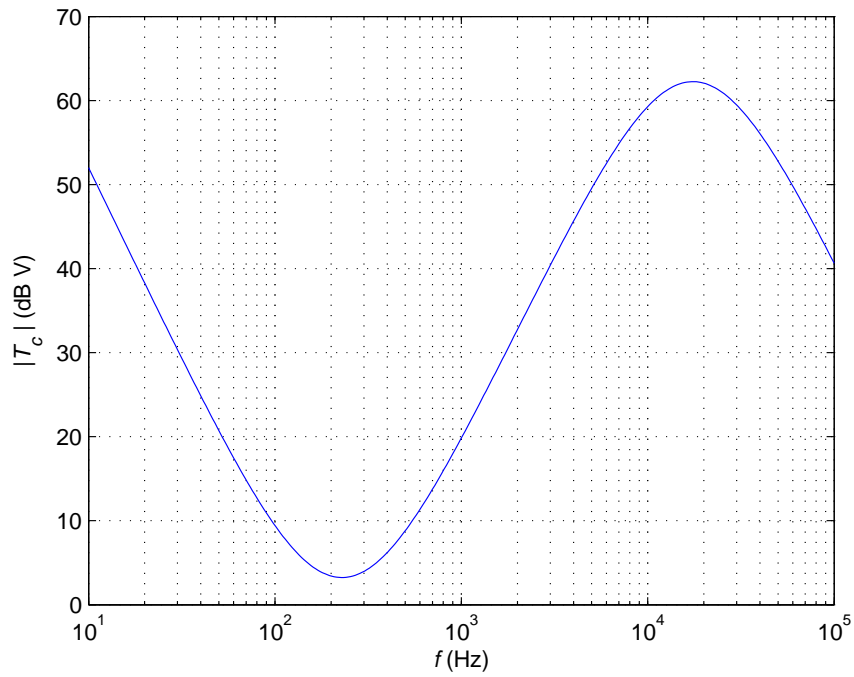

Figure 3.10: Magnitude Bode plot of the controller transfer function  $T_c$  for a buck-boost.

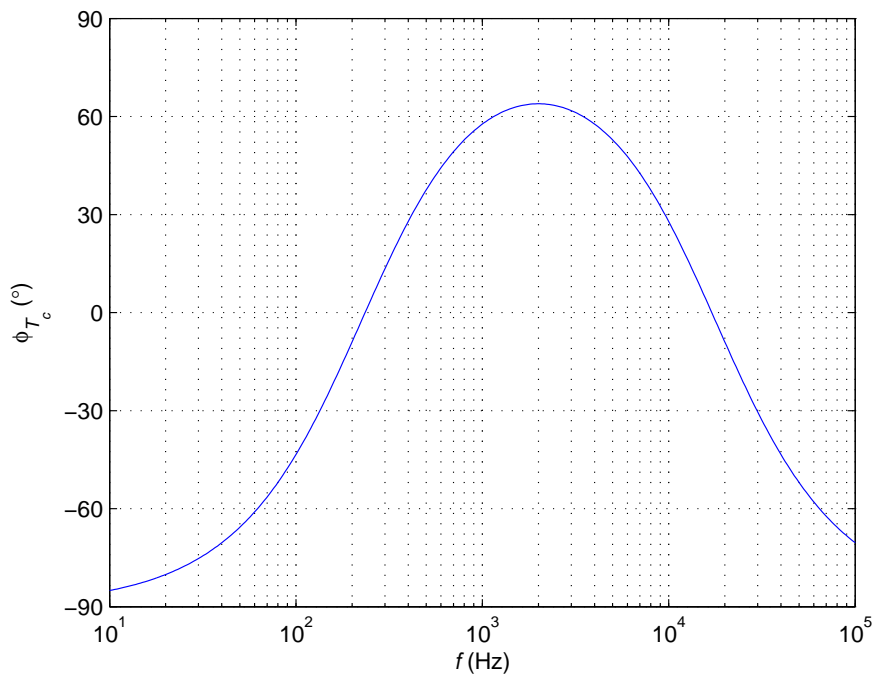

Figure 3.11: Phase Bode plot of the controller transfer function  $T_c$  for a buck-boost.

Figs: 3.12 and 3.13 show the Bode plots of  $T$ . The controller expands the bandwidth by moving the gain cross-over frequency by one kilohertz.

### 3.1.3 Closed Loop Control to Output Voltage Transfer Function

The control to output voltage closed-loop transfer function of the buck-boost is

$$T_{cl} \equiv \frac{v_o}{v_r} \Big|_{i_o=v_i=0} = \frac{T_c T_m T_p}{1 + \beta T_c T_m T_p} = \frac{\frac{1}{\beta} T}{1 + T} = \frac{1}{\beta} \frac{T}{1 + T}$$

$$T_{cl} = -\frac{1}{\beta} \frac{\beta B V_o r_C}{V_{Tm}(1-D)(R_L + r_C)} \left[ \frac{(s + \omega_{zc})^2 (s + \omega_{zn})(s - \omega_{zp})}{s(s + \omega_{pc})^2 (s^2 + 2\zeta \omega_o s + \omega_o^2)} \right]$$

$$T_{cl} = -\frac{T_x}{\beta} \left( \frac{(s + \omega_{zc})^2 (s + \omega_{zn})(s - \omega_{zp})}{s(s + \omega_{pc})^2 (s^2 + 2\zeta \omega_o s + \omega_o^2)} \right) \quad (3.19)$$

Figs: 3.14 and 3.15 show the Bode plots of  $T_{cl}$ . Figs: 3.16 and 3.17 show the discrete point Bode plots of  $T_{cl}$ .

### 3.1.4 Closed Loop Input to Output Voltage Transfer Function

The input to output voltage closed-loop transfer function of the buck-boost is

$$M_{vcl} \equiv \frac{v_o}{v_t} \Big|_{v_r=i_o=0} = \frac{M_v}{1 + T}$$

$$M_{vcl} = \left( \frac{\frac{(1-D)DR_L r_C}{L(R_L + r_C)} \frac{s + \omega_{zn}}{s^2 + 2\zeta \omega_o s + \omega_o^2}}{1 + \frac{\beta B v_o r_C}{V_{Tm}(1-D)(R_L + r_C)} \left( \frac{(s + \omega_{zc})^2 (s + \omega_{zn})(s - \omega_{zp})}{s(s + \omega_{pc})^2 (s^2 + 2\zeta \omega_o s + \omega_o^2)} \right)} \right)$$

$$= \frac{M_{vx} \frac{s + \omega_{zn}}{(s^2 + 2\zeta \omega_o s + \omega_o^2)} (s(s + \omega_{pc})^2 (s^2 + 2\zeta \omega_o s + \omega_o^2))}{s(s + \omega_{pc})^2 (s^2 + 2\zeta \omega_o s + \omega_o^2) + T_x (s + \omega_{zc})^2 (s + \omega_{zn})(s - \omega_{zp})}$$

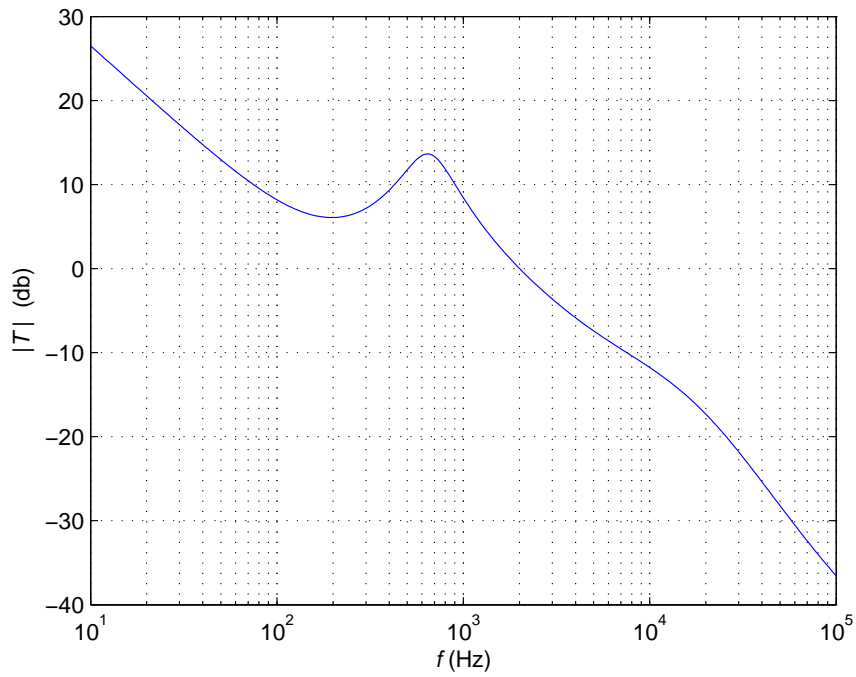

Figure 3.12: Magnitude Bode plot of the loop gain transfer function  $T$  for a buck-boost.

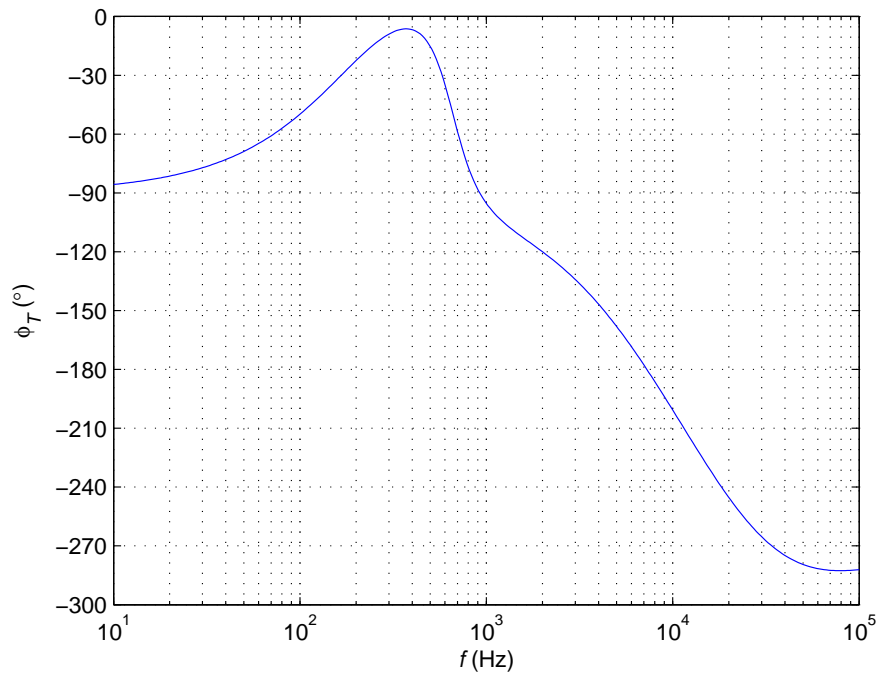

Figure 3.13: Phase Bode plot of the loop gain transfer function  $T$  for a buck-boost.

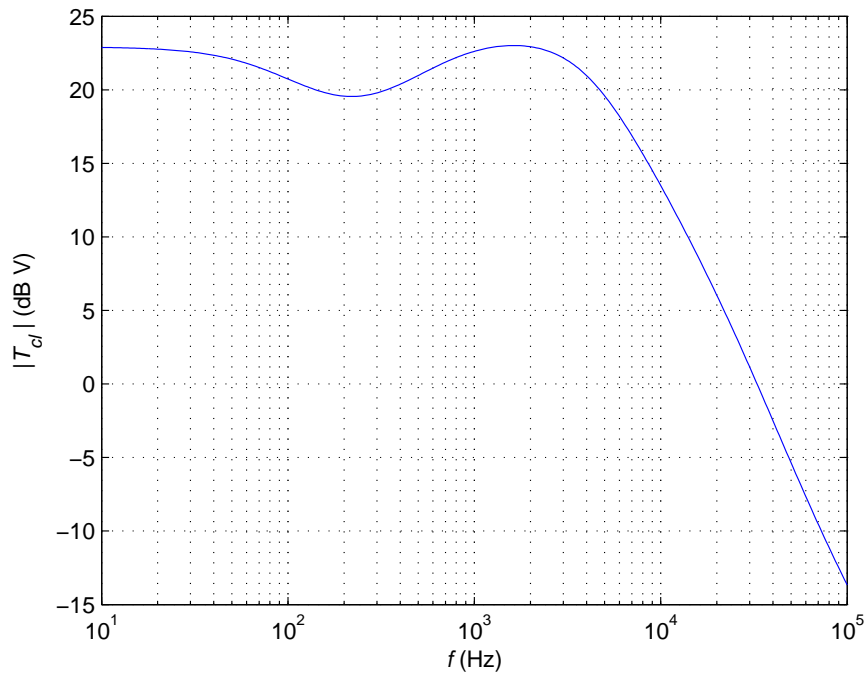

Figure 3.14: Magnitude Bode plot of the input control to output transfer function  $T_{cl}$  for a buck-boost.

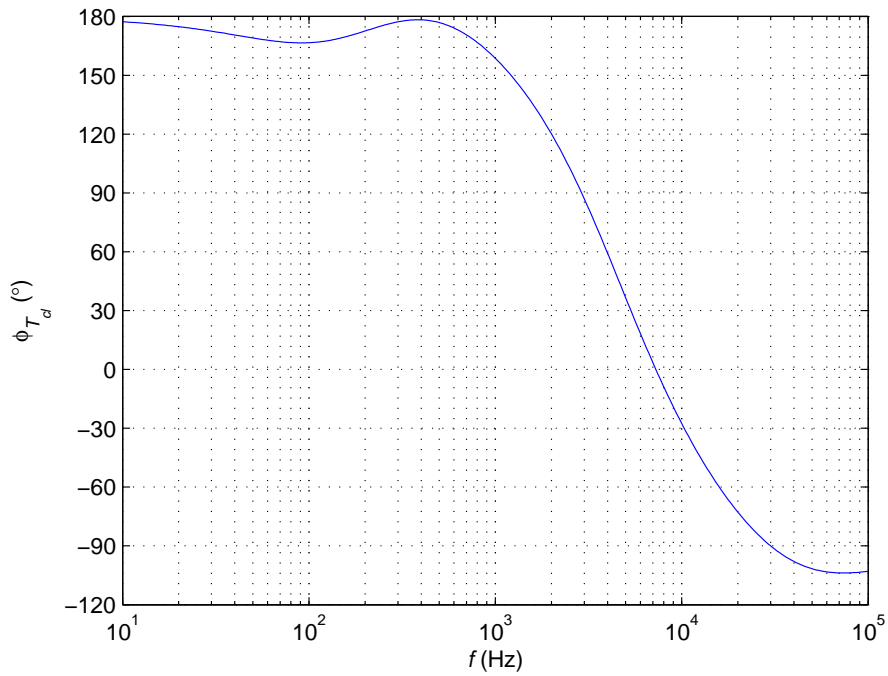

Figure 3.15: Phase Bode plot of the input control to output transfer function  $T_{cl}$  for a buck-boost.

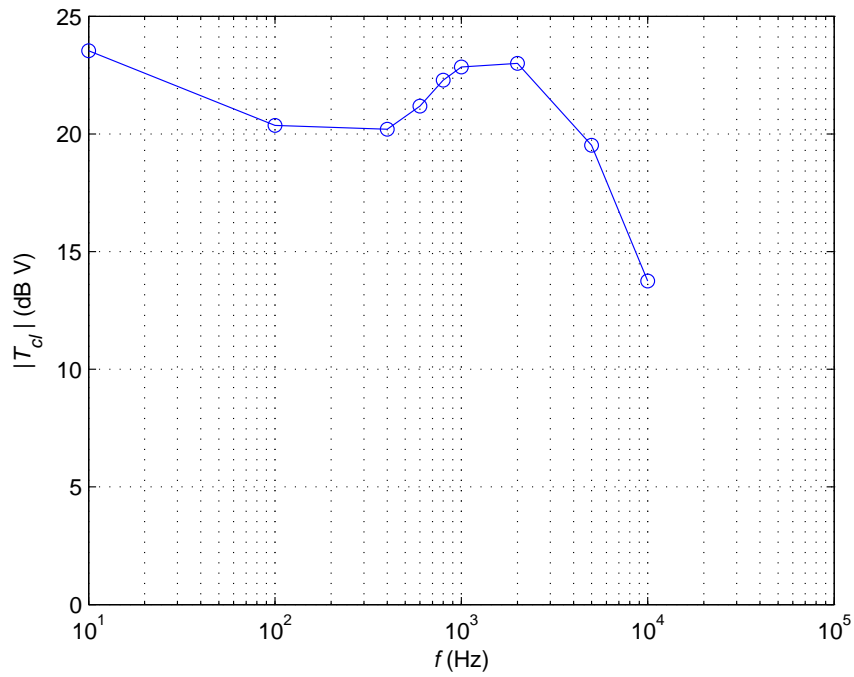

Figure 3.16: Magnitude Bode plot of the input control to output transfer function  $T_{cl}$  for a buck-boost.

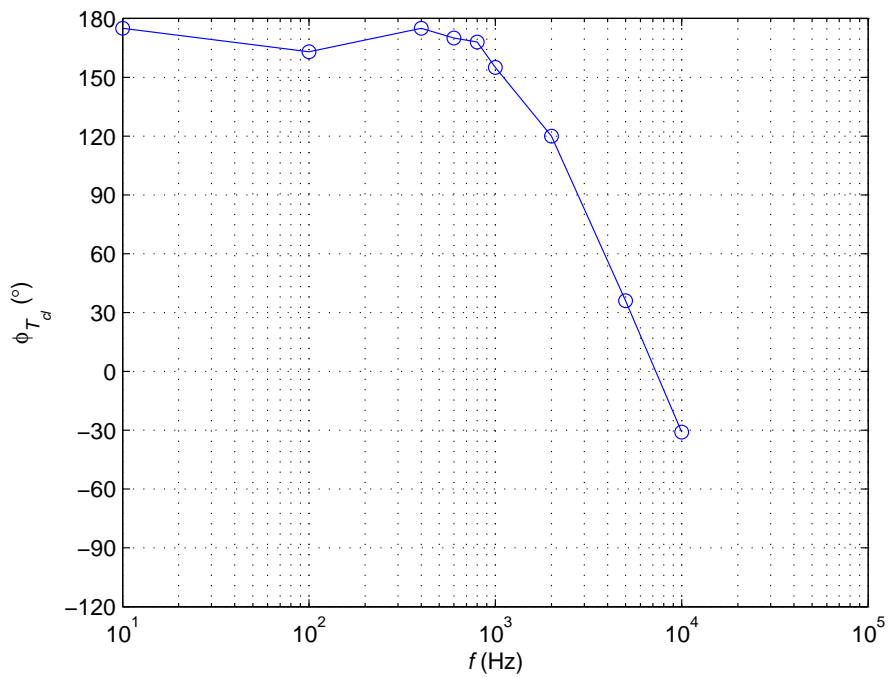

Figure 3.17: Phase Bode plot of the input control to output transfer function  $T_{cl}$  for a buck-boost.

$$= \frac{M_{vx}s(s + \omega_{pc})^2s + \omega_{zn}}{s(s + \omega_{pc})^2(s^2 + 2\zeta\omega_0s + \omega_0^2) + T_x(s + \omega_{zc})^2(s + \omega_{zn})(s - \omega_{zp})} \quad (3.20)$$

Figs: 3.18 and 3.19 show the Bode plots of input to output voltage transfer function  $M_{vcl}$ .

Figs: 3.18 and 3.19 show the discrete point Bode plots of  $M_{vcl}$ .

### 3.1.5 Closed Loop Input Impedance

Fig 3.2 is used to derive the equations for the input impedance, and setting  $v_r = 0$ ,

$$d = -\beta v_o T_c T_m \quad (3.21)$$

From the small-signal model of the buck-boost in Fig 3.2 and using KCL

$$\begin{aligned} -I_L d - D i_l + i_l + i_{Z_2} &= 0 \\ i_l(1 - D) &= I_L d - \frac{v_o}{Z_2} \end{aligned} \quad (3.22)$$

Rearranging gives

$$i_l = \frac{I_L d}{(1 - D)} - \frac{v_o}{(1 - D)Z_2}. \quad (3.23)$$

$$i_i = D i_l + I_L d \quad (3.24)$$

Substituting equations 3.21 and 3.23 into 3.24 provides the equation

$$i_i = D \left( \frac{I_L d}{(1 - D)} - \frac{v_o}{(1 - D)Z_2} \right) + I_L d$$

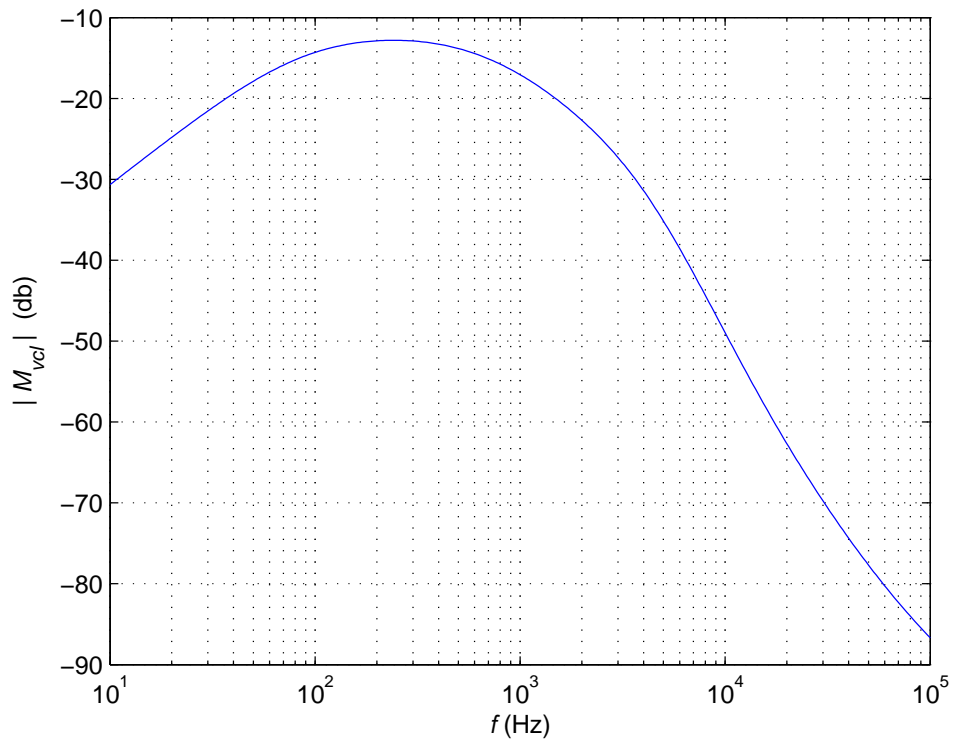

Figure 3.18: Magnitude Bode plot of the input to output voltage transfer function  $M_{vcl}$  for a buck-boost.

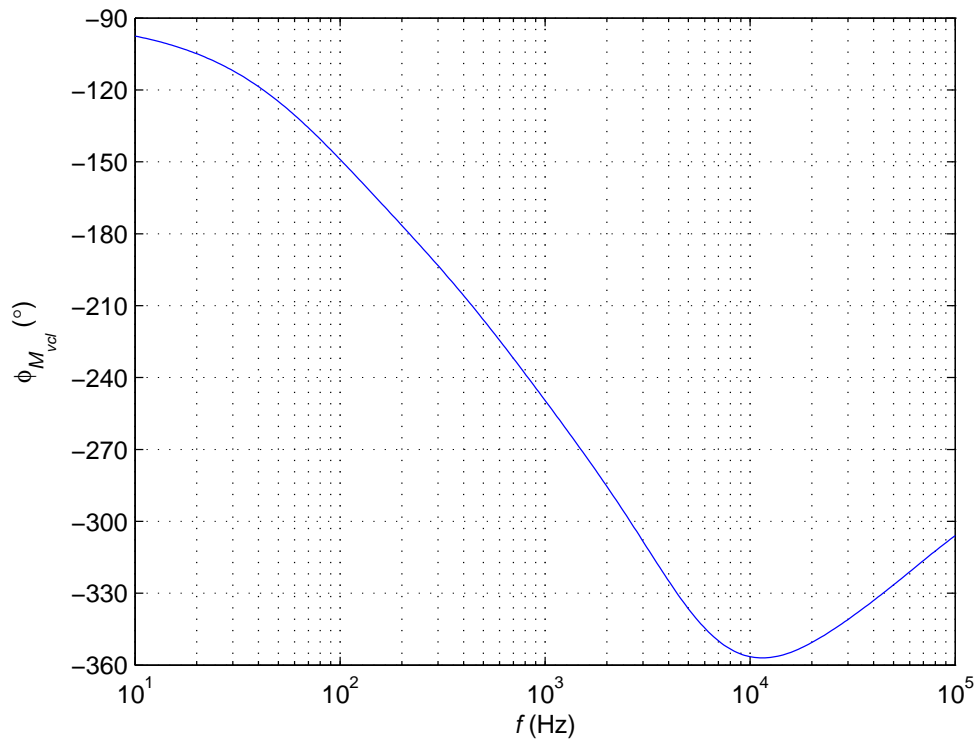

Figure 3.19: Phase Bode plot of the input to output voltage transfer function  $M_{vcl}$  for a buck-boost.

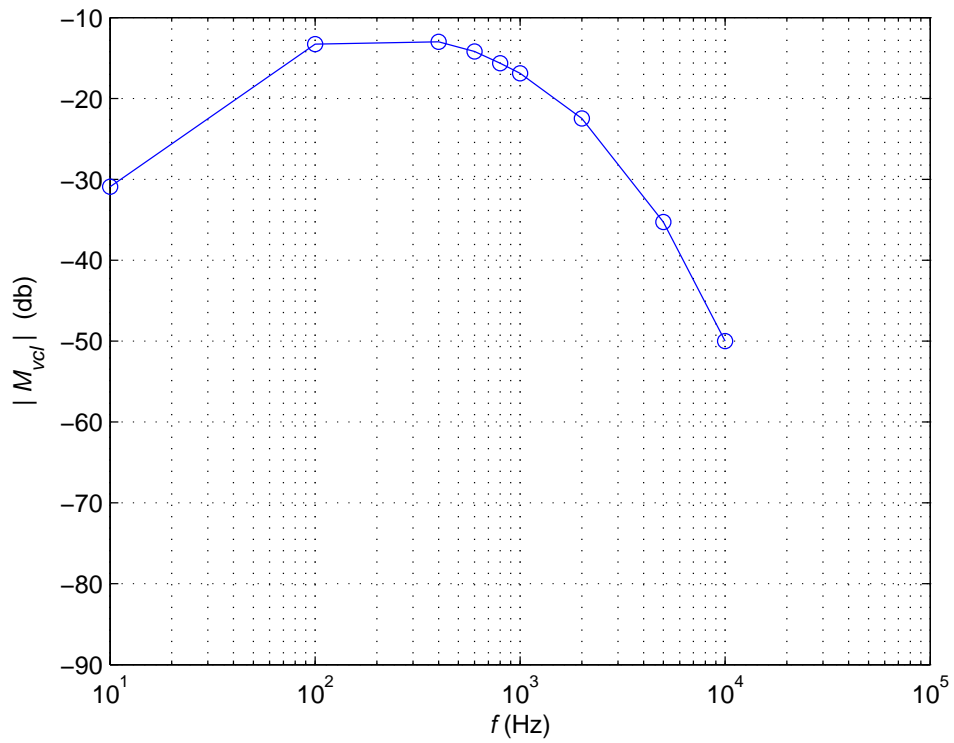

Figure 3.20: Magnitude Bode plot of the input to output voltage transfer function  $M_{vcl}$  for a buck-boost.

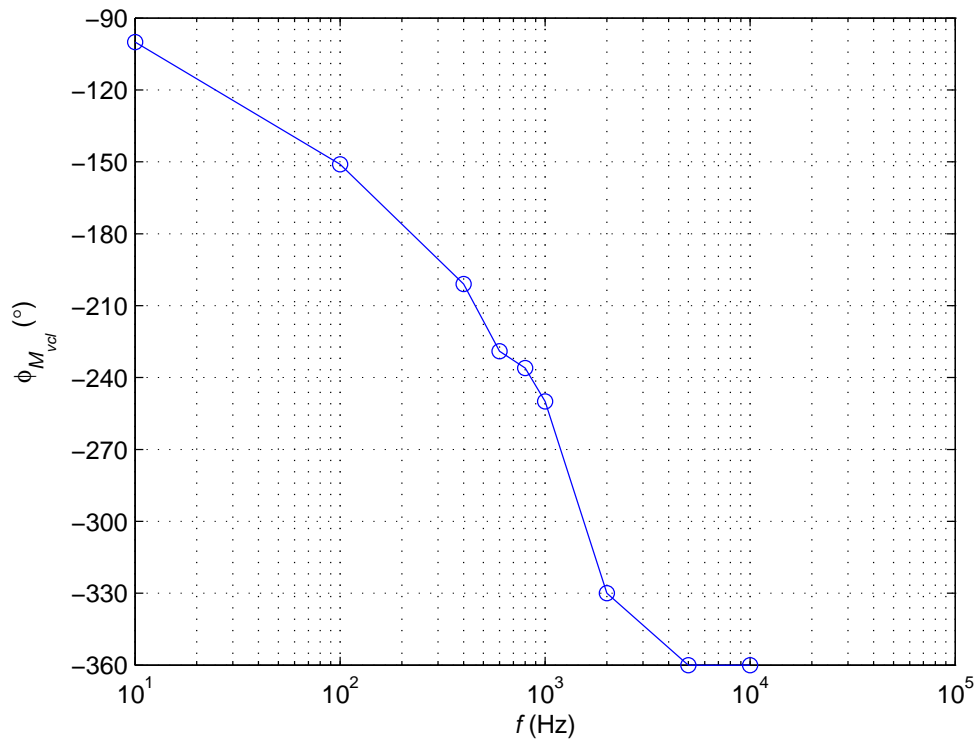

Figure 3.21: Phase Bode plot of the input to output voltage transfer function  $M_{vcl}$  for a buck-boost.

$$\begin{aligned}
i_i &= D \left( \left( \frac{I_L(-\beta v_o T_c T_m)}{(1-D)} - \frac{v_o}{(1-D)Z_2} \right) + I_L(-\beta v_o T_c T_m) \right) \\
i_i &= -\frac{v_o D}{(1-D)Z_2} - I_L \beta v_o T_c T_m \left( \frac{D}{1-D} + 1 \right) \\
i_i &= -\frac{v_o}{(1-D)Z_2} - \frac{I_L \beta v_o T_c T_m}{(1-D)} \\
i_i &= -\left( \frac{D}{(1-D)Z_2} + \frac{I_L \beta v_o T_c T_m}{(1-D)} \right) v_o. \tag{3.25}
\end{aligned}$$

DC analysis gives the equation

$$I_L = \frac{-I_o}{(1-D)} \tag{3.26}$$

and

$$I_o = \frac{v_o}{R_L}. \tag{3.27}$$

$$Y_{icl} = \frac{v_i}{i_i} \Big|_{v_r=0} = \frac{D i_l + I_L d}{v_i} \tag{3.28}$$

Substituting equations 3.26 and 3.22 into 3.28 gives the equation

$$Y_{icl} = -\left( \frac{D}{(1-D)Z_2} + \frac{I_L \beta T_c T_m}{(1-D)} \right) v_o. \tag{3.29}$$

Using the definition of  $Y_{icl}$ , equations 3.20 and dividing through by  $T_p$  yields the equation

$$= \left( \frac{I_o \beta T_c T_m}{(1-D)^2} - \frac{D}{(1-D)Z_2} \right) \frac{v_o}{v_i}$$

$$\begin{aligned}
&= \left( \frac{I_o \beta T_c T_m}{(1-D)^2} - \frac{D}{(1-D)Z_2} \right) M_{vcl} \\
&= \left( \frac{I_o \beta T_c T_m}{(1-D)^2} - \frac{D}{(1-D)Z_2} \right) \frac{M_v}{1+T}
\end{aligned}$$

$$\frac{M_v}{T_p} = \frac{\frac{(1-D)DR_L r_C}{L(R_L+r_C)} \frac{s+\omega_{zn}}{s^2+2\zeta\omega_o s+\omega_o^2}}{-\frac{V_o}{(1-D)(R_L+r_C)} \frac{(s+\omega_{zn})(s+\omega_{zp})}{s^2+2\zeta\omega_o s+\omega_o^2}}$$

$$\frac{M_v}{T_p} = \frac{(1-D)^2 R_L D}{L V_o} = \frac{D(1-D)^2}{L I_o (s - \omega_{zp})}$$

$$M_v = \left( \frac{D(1-D)^2}{L I_o (s - \omega_{zp})} \right) T_p \tag{3.30}$$

$$= \left( \frac{D(1-D)^2 T_p}{L I_o (s - \omega_{zp})} \right) \left( \frac{I_o \beta T_c T_m}{(1-D)^2} \right) = \frac{\beta T}{L(s - \omega_{zp})(1+T)}$$

$$Y_{icl} = \frac{\beta T}{L(s - \omega_{zp})(1+T)} - \frac{D M_v}{(1-D)Z_2(1+T)}$$

$$Y_{icl} = \frac{\beta}{L(s - \omega_{zp})} T_{cl} - \frac{D}{(1-D)Z_2} M_{vcl} \tag{3.31}$$

$$= \frac{L(1-D)R_L r_C (s - \omega_{zp})(s + \omega_{zn})}{\left[ \frac{\beta D(1-D)R_L r_C (s + \omega_{zn}) \left( \frac{T_x}{\beta} \right) (s + \omega_{zc})^2 (s + \omega_{zn})(s - \omega_{zp}) + D(R_L + r_C)(s + \omega_{rc})L(s - \omega_{zp}) \left( \frac{(1-D)DR_L r_C}{L r_C} \right) s(s + \omega_{pc})^2 (s + \omega_{zn})}{s(s + \omega_{pc})^2 + 2\zeta\omega_o s + \omega_o^2} + T_x (s + \omega_{zc})^2 (s + \omega_{zn})(s - \omega_{zp}) \right]} \tag{3.32}$$

$$Z_{icl} = \frac{L \left[ s(s + \omega_{pc})^2 (s^2 + 2\zeta\omega_o s + \omega_o^2) + T_x (s + \omega_{zc})^2 (s + \omega_{zn})(s - \omega_{zp}) \right]}{D T_x (s + \omega_{zc})^2 (s + \omega_{zn}) + D^2 s(s + \omega_{rc})(s + \omega_{pc})^2} \tag{3.33}$$

$$\begin{aligned}
NumZ_{icl} &= s(s + \omega_{pc})^2(s^2 + 2\zeta\omega_o s + \omega_o^2) + T_x(s + \omega_{zc})^2(s + \omega_{zn})(s - \omega_{zp}) \\
&= (s^3 + 2\omega_{pc}s^2 + \omega_{pc}s)(s^2 + 2\zeta\omega_o s + \omega_o^2) + T_x(s^2 + 2\omega_{zc}s + \omega_{zc}^2)(s^2 + (-\omega_{zp} + \omega_{zn})s - \omega_{zp}\omega_{zn}) \\
NumZ_{icl} &= s^5 + s^4(2\zeta\omega_o + 2\omega_{pc} + T_x) + s^3[\omega_o^2 + \omega_{pc}^2 + 4\omega_o\omega_{pc} + T_x((-\omega_{zp} + \omega_{zn}) + 2\omega_{zc})] + \\
&\quad s^2[2\omega_{pc}\omega_o^2 + 2\zeta\omega_o\omega_{pc}^2 + T_x(-\omega_{zp}\omega_{zn} + 2\omega_{zc}(\omega_{zn} - \omega_{zp}) + \omega_{zc}^2)] + \\
&\quad s[\omega_o^2 + \omega_{pc}^2 + T_x(-2\omega_{zc}\omega_{zp}\omega_{zn} + \omega_{zc}(-\omega_{zp} + \omega_{zn}))] - T_x\omega_{zc}^2\omega_{zp}\omega_{zn} \quad (3.34)
\end{aligned}$$

$$\begin{aligned}
DenZ_{icl} &= D^2s^4 + s^3[DT_x + 2\omega_{pc} + \omega_{rc}] + s^2[DT_x(\omega_{zn} + 2\omega_{zc}) + D^2(\omega_{pc}^2 + 2\omega_{rc}\omega_{pc})] + \\
&\quad s[DT_x(2\omega_{zc}\omega_{zn} + \omega_{zc}^2) + D^2(\omega_{rc}\omega_{pc}^2)] + DT_x\omega_{zn}\omega_{zc}^2 \quad (3.35)
\end{aligned}$$

Figs: 3.22 and 3.23 show the Bode plots of closed-loop input impedance  $Z_{icl}$ . Figs: 3.24 and 3.25 show the discrete point Bode plots of closed-loop input impedance  $Z_{icl}$ .

### 3.1.6 Closed Loop Output Impedance

The closed-loop output impedance for the buck-boost is

$$Z_{ocl} \equiv \frac{v_o}{i_o} \Big|_{v_i=v_r=0} = \frac{Z_o}{1+T}$$

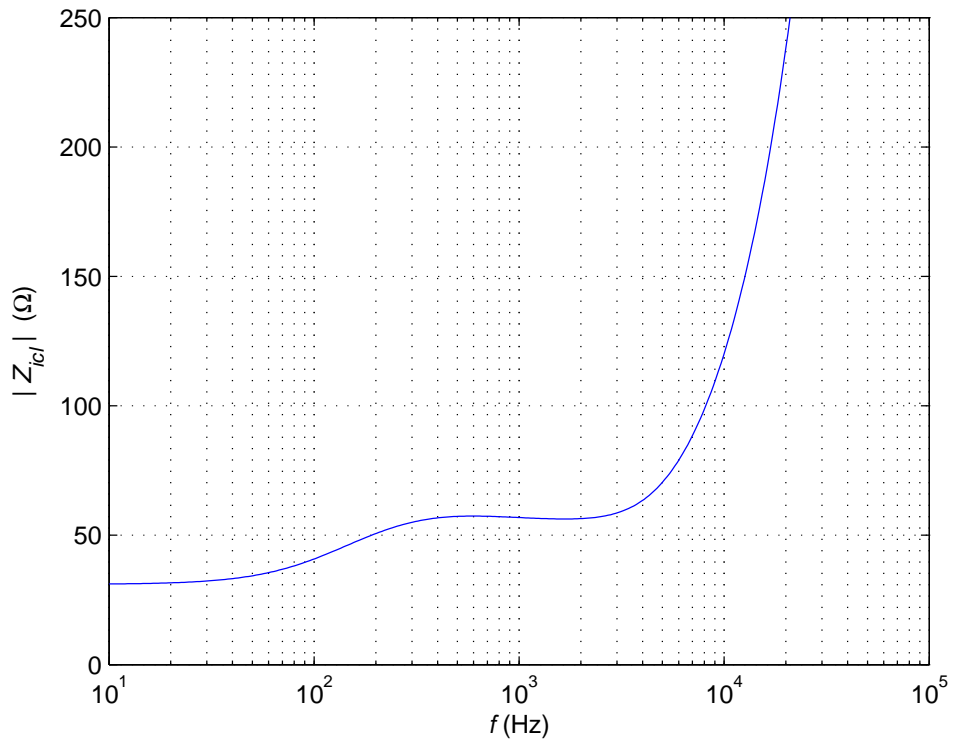

Figure 3.22: Magnitude Bode plot of the input impedance transfer function  $Z_{icl}$  for a buck-boost.

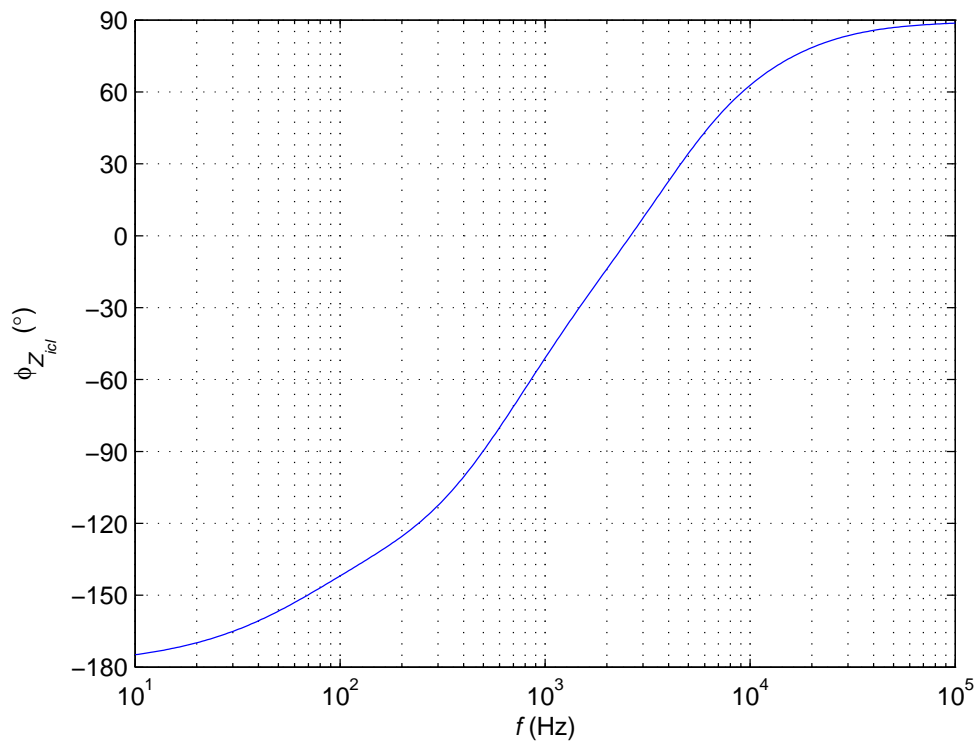

Figure 3.23: Phase Bode plot of the input impedance transfer function  $Z_{icl}$  for a buck-boost.

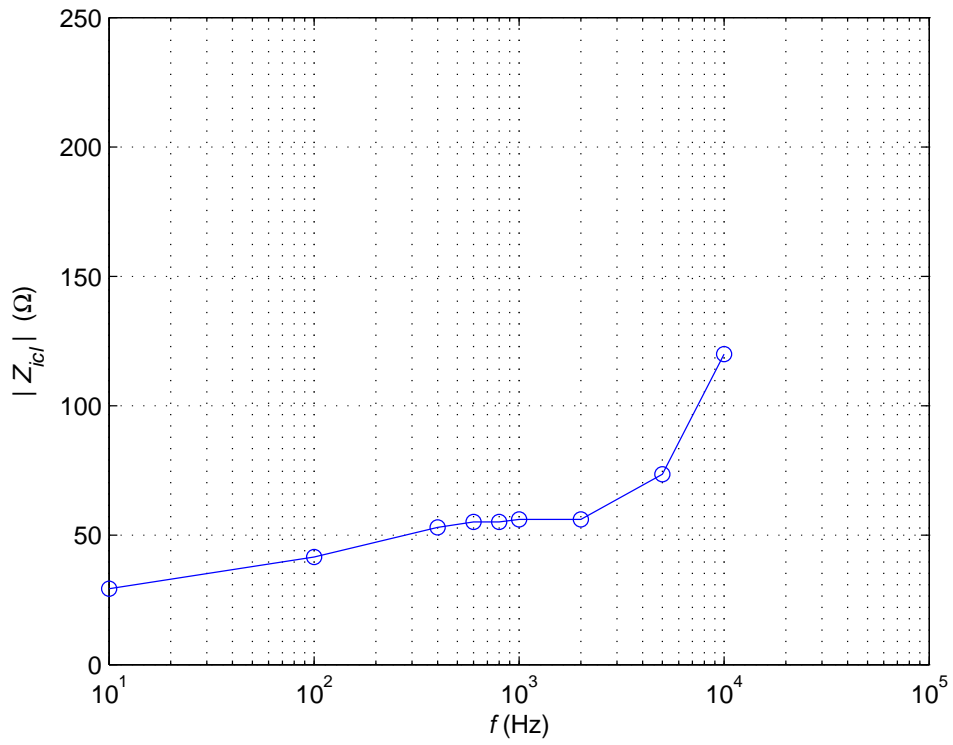

Figure 3.24: Magnitude Bode plot of the input impedance transfer function  $Z_{icl}$  for a buck-boost.

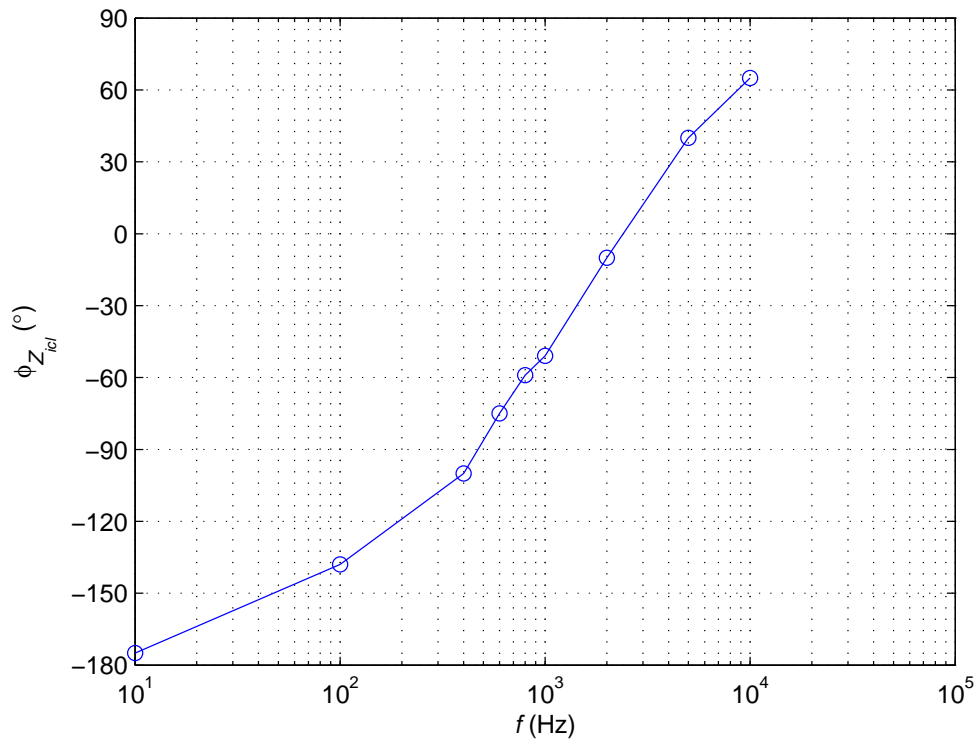

Figure 3.25: Phase Bode plot of the input impedance transfer function  $Z_{icl}$  for a buck-boost.

$$Z_{ocl} = \frac{\frac{R_L r_C}{(R_L + r_C)} \frac{(s + \omega_{rL})(s + \omega_{zn})}{s^2 + 2\zeta\omega_o s + \omega_o^2}}{1 + T}$$

$$Z_{ocl} = \frac{Z_{ox} s (s + \omega_{pc})^2 (s + \omega_{zn}) (s + \omega_{rl})}{s (s + \omega_{pc})^2 (s^2 + 2\zeta\omega_o s + \omega_o^2) + T_x (s + \omega_{zc})^2 (s + \omega_{zn}) (s - \omega_{zp})} \quad (3.36)$$

Figs: 3.26 and 3.27 show the Bode plots of closed-loop output impedance  $Z_{ocl}$ . Figs: 3.28 and 3.29 show the certain discrete point Bode plots of closed loop output impedance  $Z_{ocl}$ .

## 3.2 Closed Loop Step Responses of Buck-Boost

### 3.2.1 Closed Loop Response due to Input Voltage Step Change

Response of output voltage  $v_o$  due to a step change of 1 Volt in input voltage  $v_i$ . The total input voltage is given by equation 3.37.

$$v_I(t) = V_I(0^-) + \Delta V_I u(t) \quad (3.37)$$

$$v_i(t) = v_I(t) - V_I(0^-)$$

$$v_i(s) = L\{v_i(t)\}$$

$$v_i(s) = \frac{\Delta v_I}{s}$$

$$v_o(s) = M_{vcl}(s)v_i(s)$$

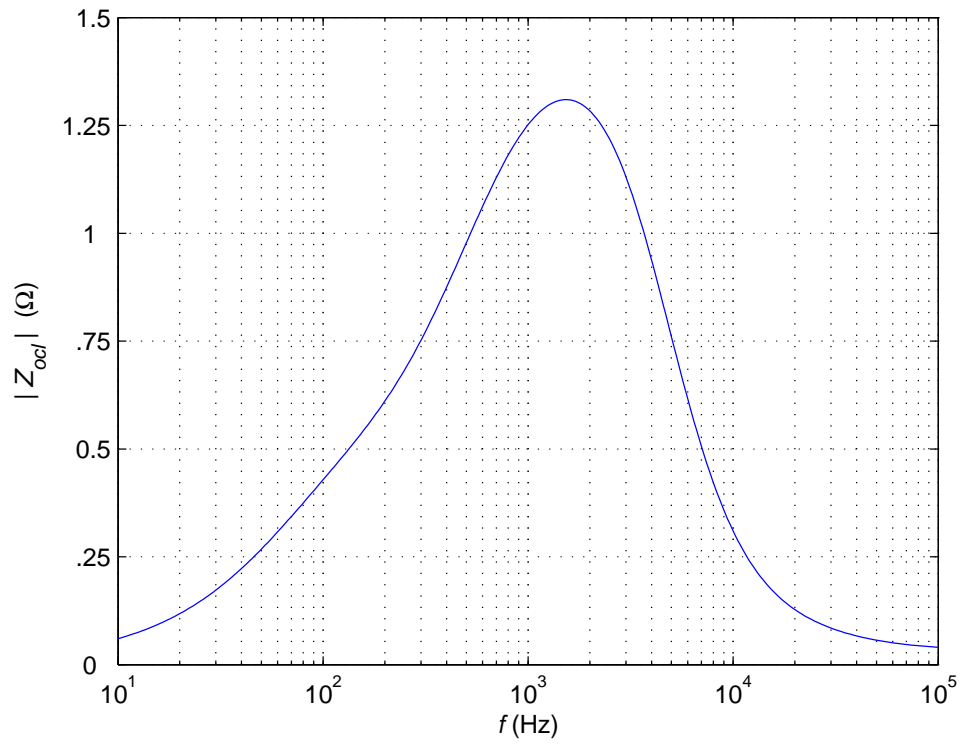

Figure 3.26: Magnitude Bode plot of the output impedance transfer function  $Z_{ocl}$  for a buck-boost.

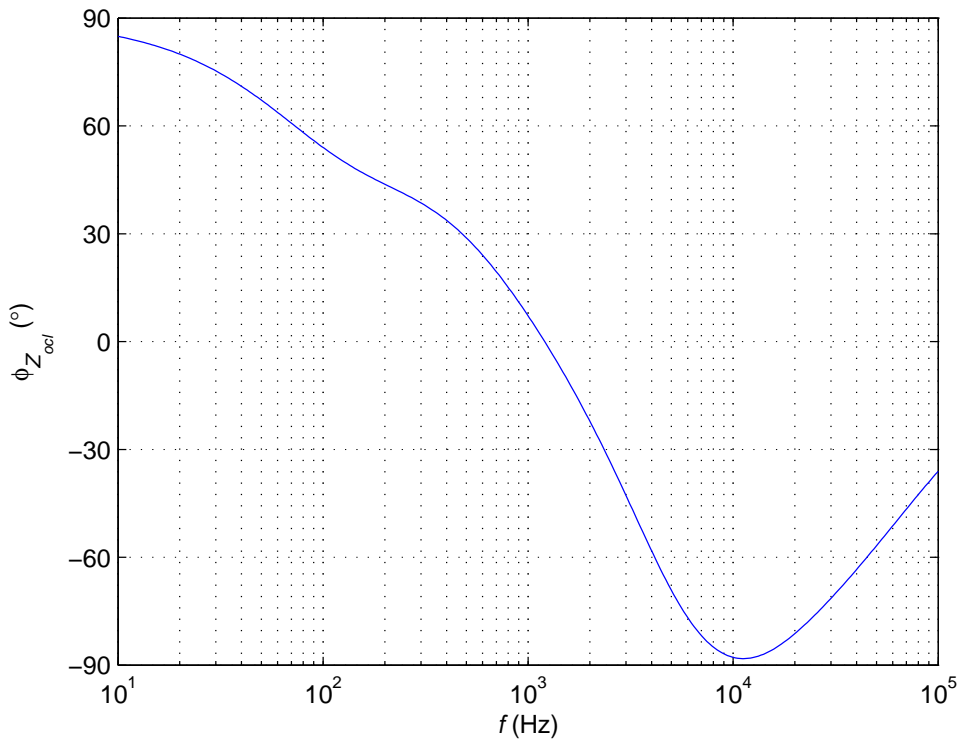

Figure 3.27: Phase Bode plot of the output impedance transfer function  $Z_{ocl}$  for a buck-boost.

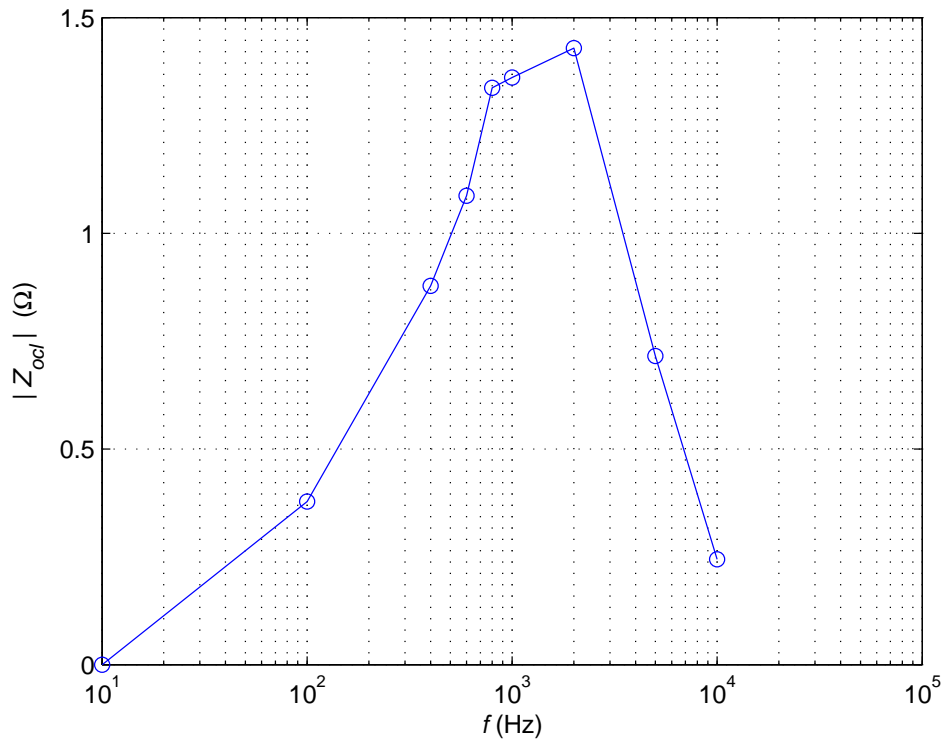

Figure 3.28: Magnitude Bode plot of the output impedance transfer function  $Z_{ocl}$  for a buck-boost.

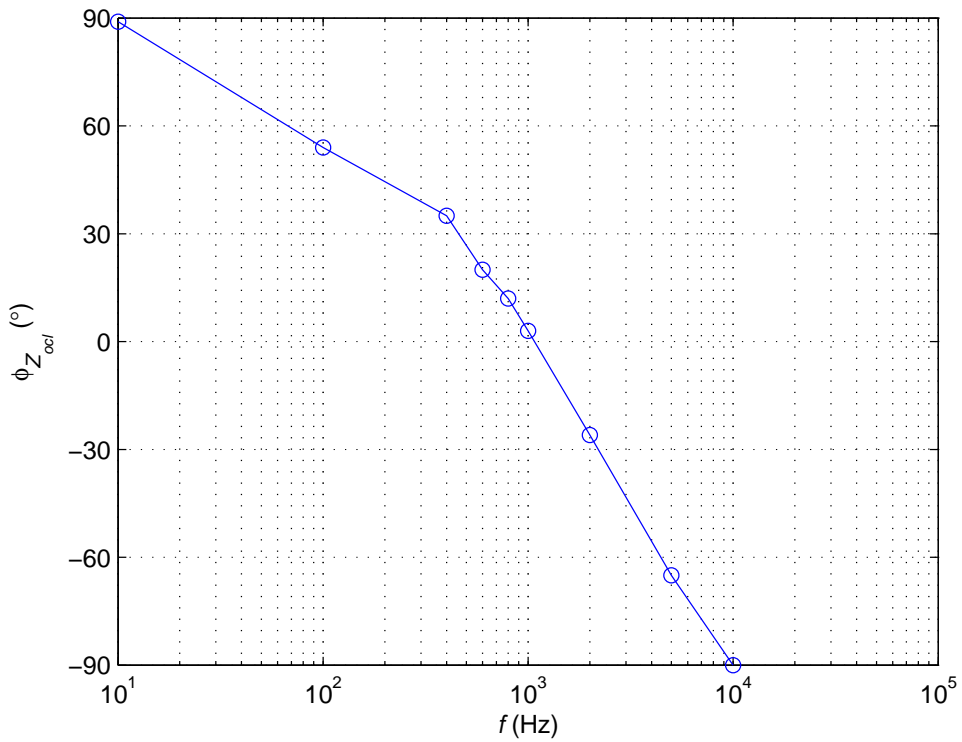

Figure 3.29: Phase Bode plot of the output impedance transfer function  $Z_{ocl}$  for a buck-boost.

$$v_o(s) = \frac{M_{vcl} \Delta v_I}{s}$$

$$v_o(t) = L\{v_o(s)\}$$

$$v_o(t) = V(0^-) + v_o(t)$$

The maximum overshoot defined in equation where  $v_o(\infty)$  is the steady state value of the normalized output voltage.

$$S_{max} = \frac{v_{omax} - v_o(\infty)}{v_o(\infty)} \quad (3.38)$$

The relative maximum ripple defined in the following equation where  $v_o(\infty)$  is the steady state value of the output voltage.

$$\delta_{max} = \frac{v_{omax} - v_o(\infty)}{v_o(\infty)}$$

where  $v_o(\infty)$  is defined as the steady state value of the output voltage. Given the measured values of the circuit are:  $V_I = 48 \text{ V}$ ,  $D = 0.407$ ,  $V_F = .7 \text{ V}$ ,  $r_{DS} = 0.4 \text{ } \Omega$ ,  $R_F = 0.02 \text{ } \Omega$ ,  $L = 334 \text{ mH}$ ,  $C = 68 \text{ } \mu\text{F}$ ,  $r_C = 0.033 \text{ } \Omega$ , and  $R_L = 14 \text{ } \Omega$ . These values lead to maximum relative transient ripple  $\delta_{max} = 0.625 \%$ . The step change due to  $v_i$  is shown in Fig: ??.

### 3.2.2 Closed Loop Response due to Load Current Step Change

Response of output voltage  $v_o$  due to a step change of 0.1 Amp in load current  $i_o$

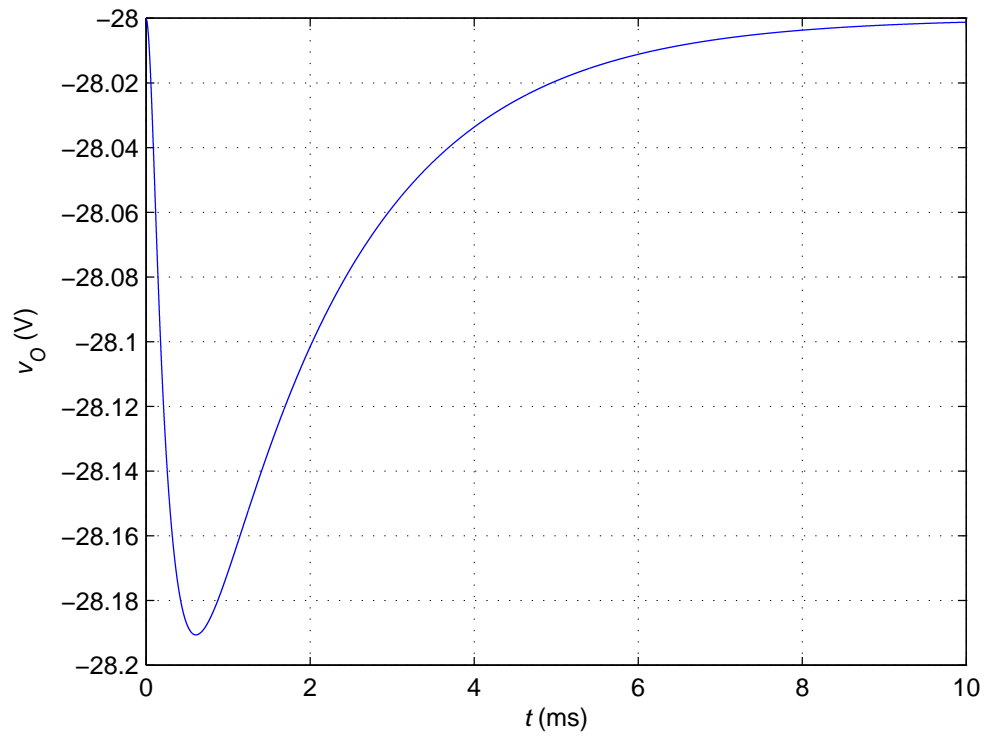

Figure 3.30: Closed Loop step response due to step change in  $v_i$ .

$$I_o(t) = I_o(0^-) + \Delta I_o u(t)$$

$$i_o(t) = i_o(t) - I_o(0^-)$$

$$i_o(s) = L\{i_o(t)\}$$

$$i_o(s) = \frac{\Delta I_o}{s}$$

$$v_o(s) = Z_{ocl}(s)i_o(s)$$

$$v_o(s) = \frac{Z_{ocl} \Delta i_o}{s}$$

$$v_o(t) = L\{v_o(s)\}$$

$$v_o(t) = V(0^-) + v_o(t)$$

The maximum overshoot defined in equation where  $v_o(\infty)$  is the steady state value of the normalized output voltage.

$$S_{max} = \frac{v_{omax} - v_o(\infty)}{v_o(\infty)} \quad (3.39)$$

$$\delta_{max} = \frac{v_{omax} - v_o(\infty)}{v_o(\infty)}$$

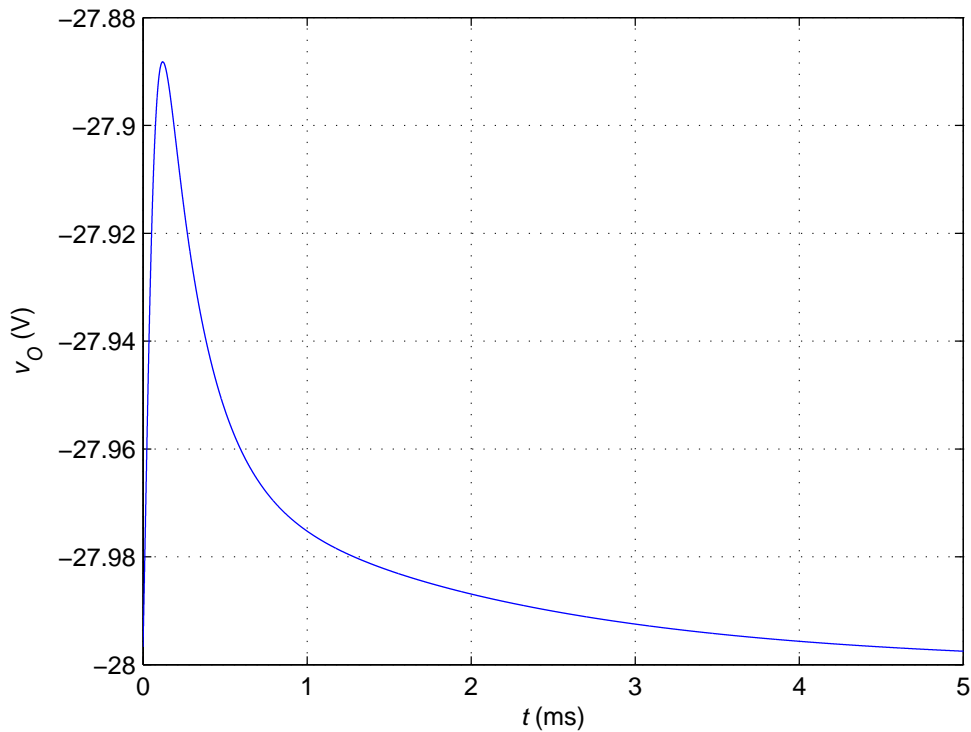

Figure 3.31: Closed Loop step response due to step change in  $i_o$ .

where  $v_o(\infty)$  is defined as the steady state value of the output voltage. Given the measured values of the circuit are:  $V_I = 48$  V,  $D = 0.407$ ,  $V_F = 0.7$  V,  $r_{DS} = 0.4$   $\Omega$ ,  $R_F = .02$   $\Omega$ ,  $L = 334$  mH,  $C = 68$   $\mu$ F,  $r_C = 0.033$   $\Omega$ , and  $R_L = 14$   $\Omega$ . These values lead to a maximum relative transient ripple of  $\delta_{max} = 0.375$  %. The step change due to load current  $i_o$  is shown in Fig: 3.32 .

### 3.2.3 Closed Loop Response due to Reference Voltage Step Change

Response of output voltage  $v_o$  due to a step change of 1 volt in reference voltage  $v_r$

$$v_R(t) = V_R(0^-) + \Delta V_R u(t)$$

$$v_r(t) = v_R(t) - V_R(0^-)$$

$$v_r(s) = L\{v_r(t)\}$$

$$v_r(s) = \frac{\Delta v_R}{s}$$

$$v_o(s) = T_{pcl}(s)v_r(s)$$

$$v_o(s) = \frac{T_{pcl} \Delta v_R}{s}$$

$$v_o(t) = L\{v_o(s)\}$$

$$v_o(t) = V(0^-) + v_o(t)$$

The maximum undershoot is defined as

$$S_{max} = \frac{v_{omax} - v_o(\infty)}{v_o(\infty)} \quad (3.40)$$

where  $v_o(\infty)$  is defined as the steady state value of the normalized output voltage. The relative maximum ripple defined in equation where  $v_o(\infty)$  is the steady state value of the output voltage.

$$\delta_{max} = \frac{v_{omax} - v_o(\infty)}{v_o(\infty)}$$

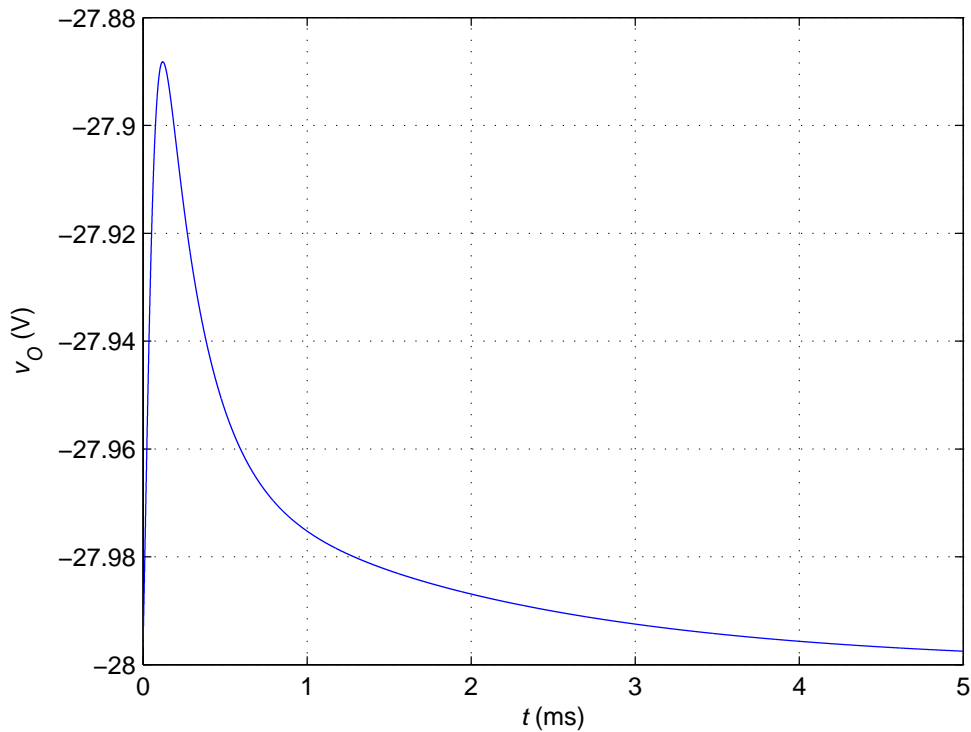

Figure 3.32: Closed Loop step response due to step change in  $v_r$ .

Given the measured values of the circuit are:  $V_I = 48 \text{ V}$ ,  $D = 0.407$ ,  $V_F = 0.7 \text{ V}$ ,  $r_{DS} = 0.4 \Omega$ ,  $R_F = 0.02 \Omega$ ,  $L = 334 \text{ mH}$ ,  $C = 68 \mu\text{F}$ ,  $r_C = 0.033 \Omega$ , and  $R_L = 14 \Omega$ . These values lead to a maximum undershoot of  $S_{max} = 28.57 \%$  and a maximum relative transient ripple  $\delta_{max} = 9.25 \%$ . The step change due to  $v_r$  is shown in Fig: ??.

### 3.3 Closed Loop Step Responses using PSpice

#### 3.3.1 Closed Loop Response of buck-boost

A circuit showing the closed-loop buck-boost and control circuit is shown in Fig 3.33. The measured values of the circuit are:  $V_I = 48 \text{ V}$ ,  $D = 0.389$ ,  $L = 334 \text{ mH}$ ,  $C = 68 \mu\text{F}$ ,  $r_C = 0.033 \Omega$ ,  $r_L = 0.32 \Omega$  and  $R_L = 14 \Omega$ . An International Rectifier IRF150 power MOSFET

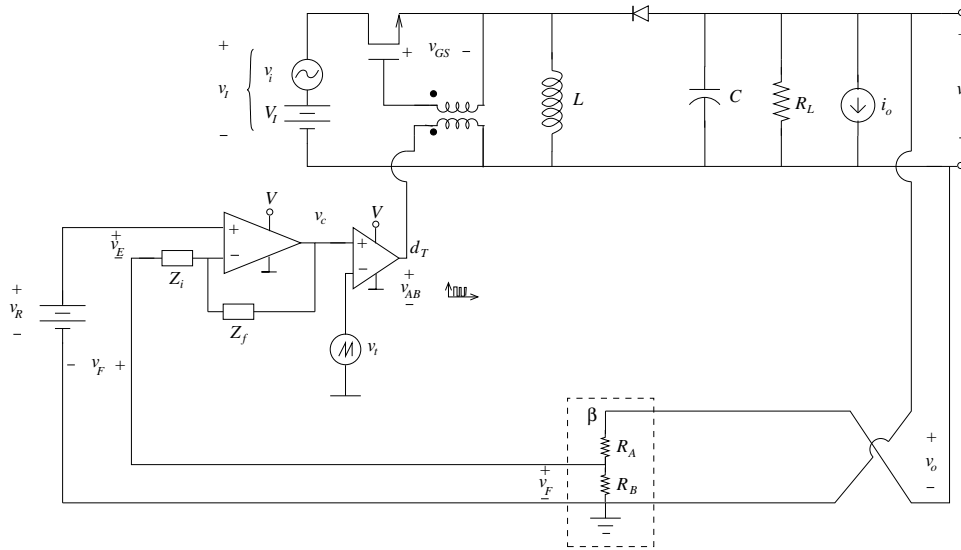

Figure 3.33: Closed loop buck-boost model with disturbances.

is selected, which has a  $V_{DSS} = 100\text{ V}$ ,  $I_{SM} = 40\text{ A}$ ,  $r_{DS} = 55\text{ m}\Omega$ ,  $C_o = 100\text{ pF}$ , and  $Q_g = 63\text{ nC}$ . Also, a International Rectifier 10CTQ150 Schottky Common Cathode Diode is selected with a  $V_R = 100\text{ V}$ ,  $I_{F(AV)} = 10\text{ A}$ ,  $V_F = 0.73\text{ V}$  and  $R_F = 28\text{ m}\Omega$ . The control circuit contains a National Semiconductor LF357 op-amp. The op-amp selected is not rail to rail and has a  $V_{max} = \pm 18\text{ V}$ . The voltage divider values for  $\beta$  are  $R_A = 12\text{ k}\Omega$  and  $R_B = 910\Omega$ . The control circuit is shown in Fig 3.9 and contains the following values:  $R_1 = 100\text{ k}\Omega$ ,  $R_2 = 56\text{ k}\Omega$ ,  $R_3 = 470\Omega$ ,  $R_{bd} = 100\text{ k}\Omega$ ,  $C_1 = 12\text{ nF}$ ,  $C_2 = .15\text{ nF}$ ,  $C_3 = 6.8\text{ nF}$ , and  $h_{11} = 846\Omega$ .

The output voltage of the buck-boost without any disturbances or step changes can be seen in Fig 3.34. The relative maximum overshoot is  $\delta_{max} = 1.78\%$ , and a settling time within two percent of steady state value in 2.2 ms.

### 3.3.2 Closed Loop Response due to Input Voltage Step Change

The PSpice circuit with step change in input voltage is shown in Fig 3.35. An addition voltage pulse source of 1 volt was added with a delay of 10 ms so that the circuit ran for sufficient time to reach steady state value before the disturbance is activated.

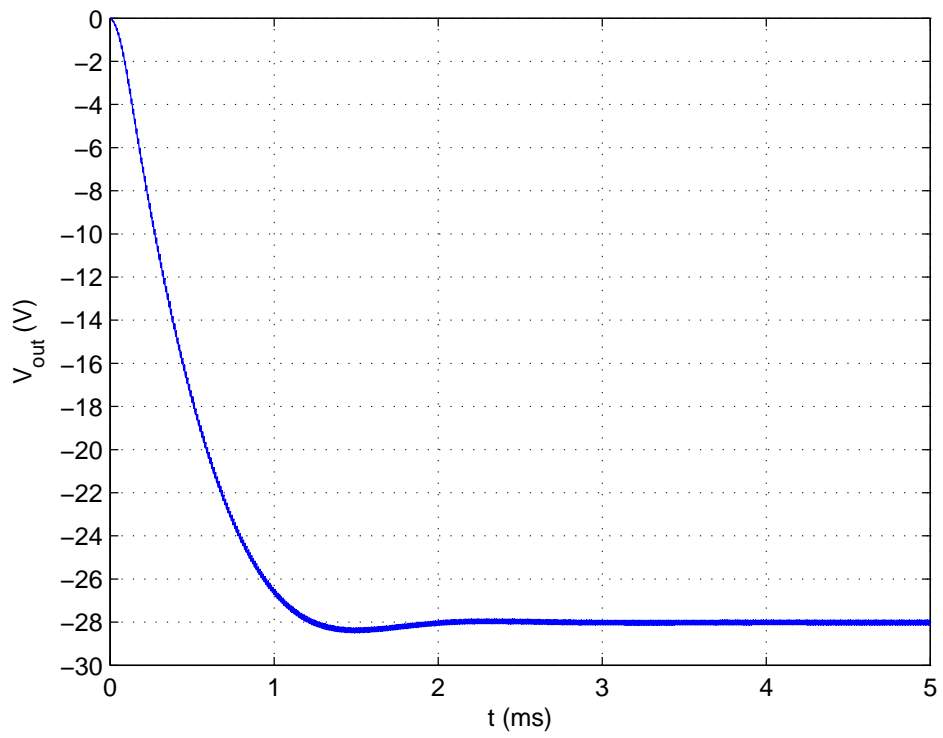

Figure 3.34: Closed loop buck-boost response without disturbances.

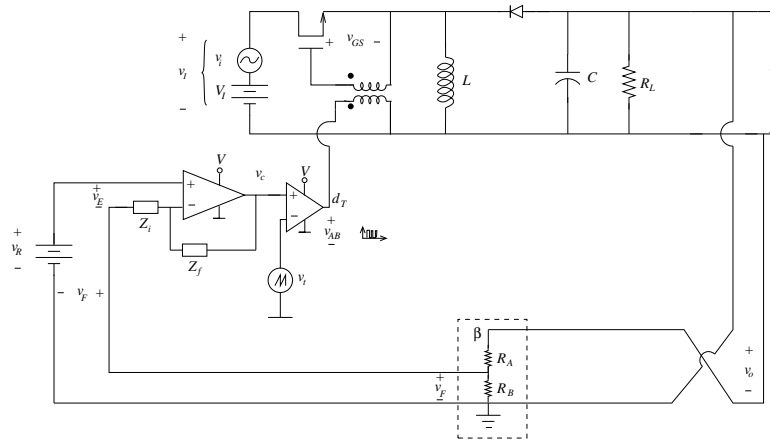

Figure 3.35: PSpice model of Closed Loop buck-boost with step change in input voltage.

The output voltage of the buck boost can be seen in Fig 3.36. The voltage ripple is 0.22 volts contained between  $-28.65V$  and  $-28.3V$ , the average value of steady state is  $-28.475V$ . The maximum overshoot is  $S_{max} = 72\%$  and settling time is within two percent in  $5ms$  which contains the ripple of steady state value. The relative maximum overshoot is  $\delta_{max} = 0.526\%$ . The reason steady state did not return to  $-28$  as predicted by MatLab is because of the non-ideal op-amps. The gain is only 667, not infinite, as shown in the MatLab model.

### 3.3.3 Closed Loop Response due to Load Current Step Change

The PSpice circuit with step change in load current is shown in Fig 3.37. An additional current pulse source of 0.1 Amp was added with a delay of 10 ms so that the circuit ran for sufficient time to reach steady state value, and then the disturbance is activated.

The output voltage of the buck boost can be seen in Fig 3.38. The voltage ripple is .35 V, and the output voltage is contained between  $-27.81V$  and  $-28.16V$ . the average value of steady state is  $-27.99V$ . The relative maximum overshoot  $\delta_{max} = 1.07\%$  and settling time is within two percent in 2.2ms which contains the ripple of steady state value.

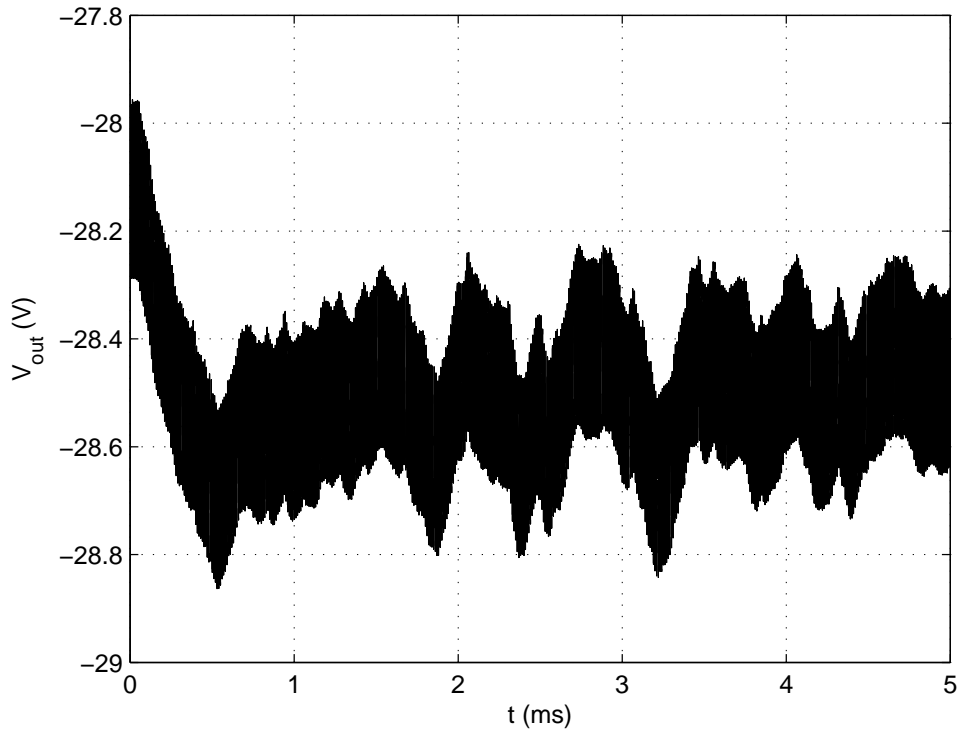

Figure 3.36: Closed Loop step response due to step change in input voltage using PSpice.

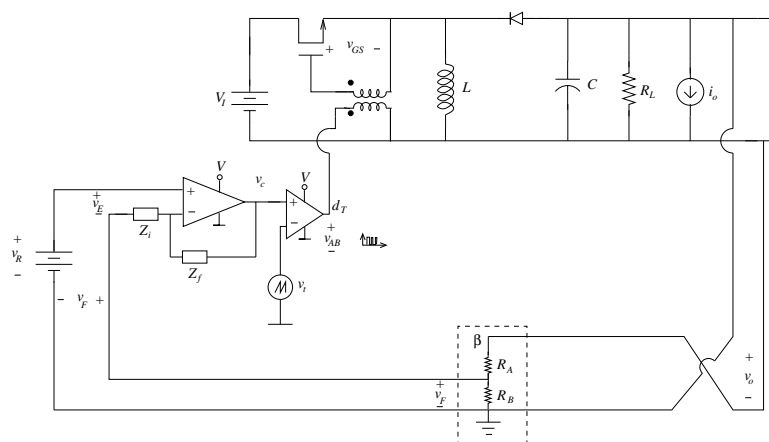

Figure 3.37: PSpice model of Closed Loop buck-boost with step change in load current.

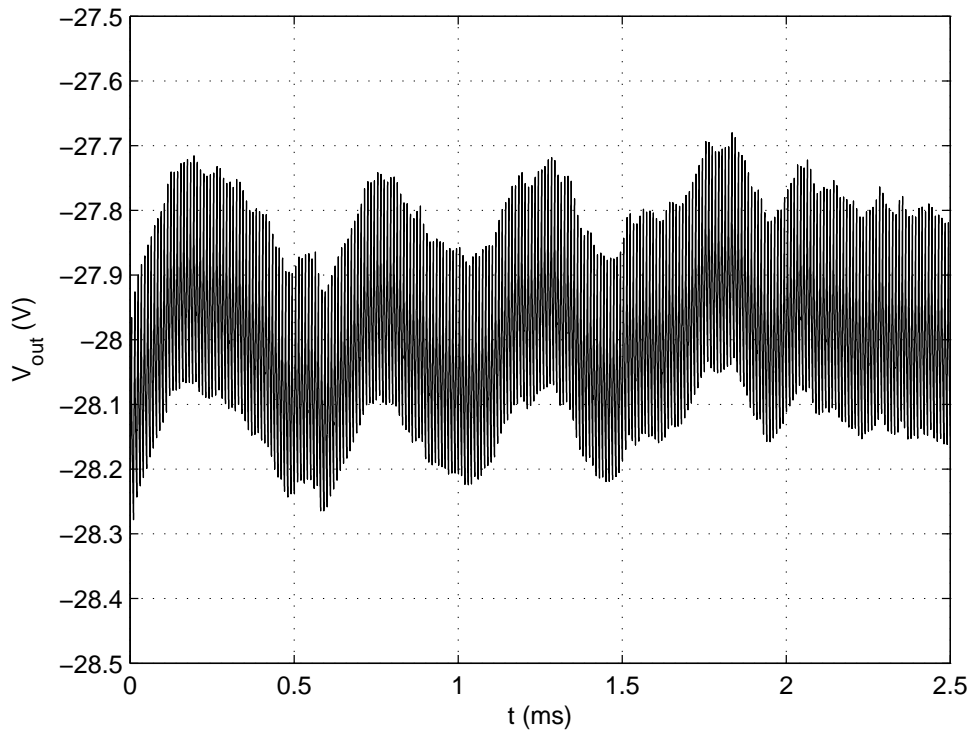

Figure 3.38: Closed Loop step response due to step change in load current using PSpice.

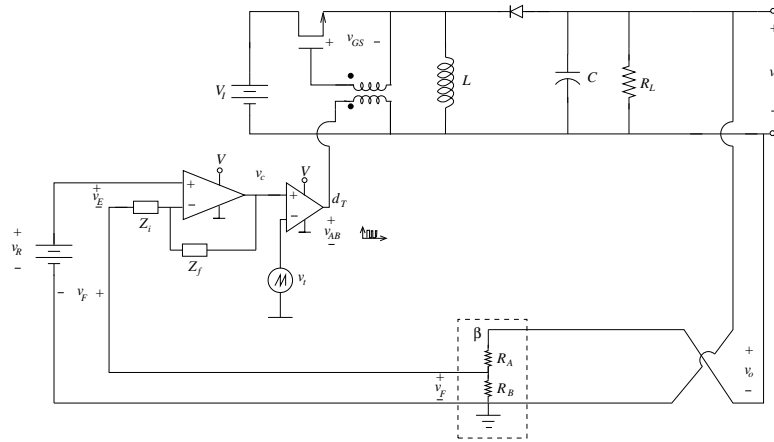

Figure 3.39: PSpice model of Closed Loop buck-boost with step change in duty cycle.

### 3.3.4 Closed Loop Response due to Reference Voltage Step Change

The PSpice circuit with step change in reference voltage is shown in Fig 3.39. The Piecewise Linear function in PSpice is utilized to create a step function in the reference voltage.

The output voltage of the buck boost can be seen in Fig3.40 . The voltage ripple is 0.42 V, the average voltage of steady state is  $-30\text{ V}$  and the output voltage is contained between the bounds of  $-30.13\text{ V}$  and  $-29.85\text{ V}$  . The maximum overshoot  $S_{max} = 675\%$ , and settling time is within two percent in 6ms, which contains the ripple of steady state value. The relative maximum overshoot is  $\delta_{max} = 45\%$

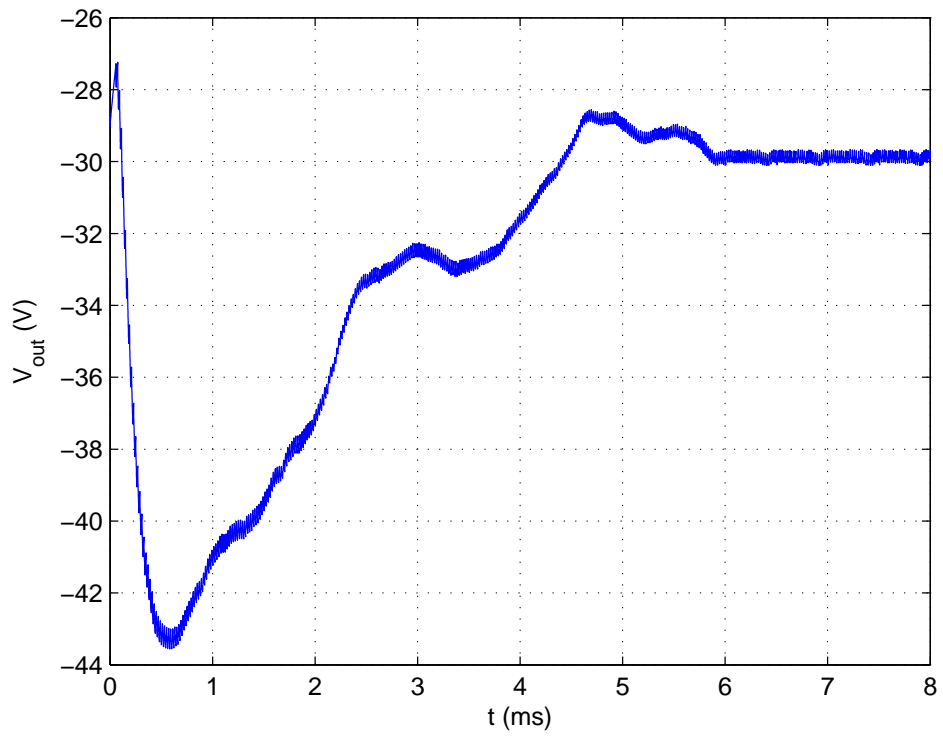

Figure 3.40: Closed Loop step response due to step change in reference voltage using PSpice.

# 4 Conclusion

## 4.1 Contributions

The principles on operation of open-loop and closed-loop of the dc-dc buck-boost converter is discussed. Also, design and analysis of an intergral-lead type III controller for the closed-loop buck-boost is discussed. Equations for the transfer functions and step responses for a selected prechosen design of a dc-dc buck-boost converter. For the selected design, the step response and Bode plots is found using both matlab and PSpice. The observations can be summarized as:

1. The discrete point Bode plots found coincide with the theoretical Bode plots given by MatLab.
2. The step responses determined by PSpice are consistent with the theoretical step responses given by MatLab.
3. Stabilizing the buck-boost converter is a challenge because of the RHP zero but can be accomplished by using a type III controller.
4. The theoretical phase shift achieved by the integral-lead is  $180^\circ$  but in reality only  $150^\circ$  to  $160^\circ$  can be achieved.
5. The magnitude of input to output voltage transfer function  $M_v$  is reduced by negative feedback.

## 4.2 Future Work

Improving the response time, efficiency and reducing losses is a major challenge because of the practical limitations of a buck-boost converter. Selecting the MOSFET, diode, and current transformer for experimentation for small-signal applications is a good choice for future research. Voltage mode control and Current mode control of the PWM dc-dc buck-boost. As well as distinguish the characteristics of finding a Bode plot without using discrete points. Also, finding a methodology for the characteristics of a small-signal model.

# Appendix A

$V_O$  DC output voltage  
 $v_o$  AC component of the output voltage

$v_O$  Total output voltage

$I_O$  DC output current

$i_o$  AC component of the output current

$i_O$  Total output current

$d$  AC component of duty cycle

$D$  DC component of duty cycle

$V_I$  DC input Voltage

$v_i$  AC component of the input voltage

$v_I$  Total input voltage

$r_{DS}$  Parasitic on-resistance of the MOSFET

$r_L$  Parasitic componet of Inductor

$R_F$  Forward resistance of the diode

$V_F$  Forward voltage drop of diode

$V_{SD}$  DC component of the voltage between MOSFET and Diode

$v_{sd}$  AC component of the voltage between MOSFET and Diode  
 $r$  Combination of parasitic components of mosfet, diode, and inductor  
 $C$  Capacitor  
 $L$  Inductor  
 $I_L$  DC inductor current  
 $i_l$  AC component of inductor current  
 $i_L$  Total inductor current  
 $r_C$  Parasitic component of capacitor  
 $R_L$  Load resistor  
 $Z_1$  Impedance caused by the series combination of  $r$  and inductor  
 $Z_2$  Impedance caused by the parallel combination of load resistor and capacitor  
 $T_p$  Open-loop input control to output voltage transfer function  
 $M_v$  Open-loop input to output voltage transfer function, audio susceptibility  
 $Z_i$  Open-loop input impedance transfer function  
 $Z_o$  Open-loop output impedance transfer function  
 $T_{cl}$  Closed-loop input control to output voltage transfer function  
 $M_{vcl}$  Closed-loop input to output voltage transfer function, audio susceptibility  
 $Z_{icl}$  Closed-loop input impedance transfer function  
 $Z_{ocl}$  Closed-loop output impedance transfer function  
 $T_c$  Compensator transfer function  
 $T$  Loop gain transfer function

$T_m$  Modulator transfer function

$T_{mp}$  Modulator and open-loop input control to output transfer function

$T_k$  Gain of the system before control added

$A$  Forward gain  $T_c T_{mp}$

# References

1. M. K. Kazimierczuk, Class notes, EE 742-Power Electronics II, Wright State University, Winter 2006.
2. R. D. Middlebrook and S. Cuk, *Advances in Switched-Mode Power Conversion*, vols. I, II, and III. Pasadena, CA: TESLACO, 1981.
3. J. G. Kassakian, M. F. Schlecht, and G. C. Verghese, *Principles of Power Electronics*, Reading, Mass.: Addison-Wesley, 1991.
4. N. Mohan, T. M. Undeland, and W. P. Robbins, *Power Electronics: Converters, Applications, and Design*, 3rd Ed., New York: John Wiley & Sons, 2004.
5. DATEL, Inc., *Power Converter Theory*, Available: [www.datel.com](http://www.datel.com).
6. G. Massobrio and P. Antognetti, *Semiconductor Device Modeling with SPICE*, 2nd Ed. New York: McGraw-Hill, 1993.
7. [www.irf.com](http://www.irf.com).
8. [www.national.com](http://www.national.com)
9. M. K. Kazimierczuk, N. Sathappan, and D. Czarkowski, "Voltage-mode controlled PWM buck dc-dc converters," *Proc. of the IEEE National Aerospace Conf. (NAECON'93)*, Dayton, OH, May 24-28, 1993, vol. 1, pp. 1253-1256.
10. M. K. Kazimierczuk and R. Cravens, II, and A. Reatti, "Closed-loop input impedance of

the PWM buck-derived dc-dc converters", *IEEE International Conference on Circuits and Systems*, London, U.K., May 30-June 2, 1994, vol. 6 pp. 61-64.

11. M. K. Kazimierczuk and R. Cravens, II, "Closed-loop input impedance of a voltage-mode-controlled PWM buck-derived dc-dc converters," *IEEE 37th Midwest Symposium on Circuits and Systems*, Lafayette, LA, August 3-5, 1994, pp. 1253-1256.
12. M. K. Kazimierczuk and R. Cravens, II, "Closed-loop characteristics of voltage-mode-controlled PWM boost dc-dc converter with an integral-lead controller," *Journal of Circuits, Systems, and Computers*, vol. 4, no.4 pp. 429-458, December 1994.
13. M. K. Kazimierczuk and R. Cravens, II, "Input impedance of a closed-loop PWM boost dc-dc converter for CCM," *IEEE International Conference on Circuits and Systems*, Seattle, WA, April 30-May 3, 1995, pp. 2047-2050.